

OPERATION MANUAL

OM Series

Quarter-Turn Electrical Actuator

INDEX

- OVERVIEW 1
- IMPORTANT NOTICES 2
- STANDARD MOUNTING 3
- SPECIFICATION 4
- STORAGE INFORMATION 6
- LUBRICATION 6
- INSTALLATION 7
- WIRING DIAGRAM 8
 - OM-1 , OM-A , OM-A-M 12V , 24V DC On-Off Controller 9
 - OM-1 , OM-A , OM-A-M 12V , 24V AC On-Off Controller 10
 - OM-1 , OM-A , OM-A-M 110V , 220V AC 1-Phase On-Off Controller 11
 - OM-1 , OM-A , OM-A-M 110V , 220V AC 1-Phase On-Off Controller , 75% duty cycle 12
 - OM-1 , OM-A , OM-A-M 110V , 220V AC 1-Phase On-Off Controller , Coupling Board 13
 - OM-1 , OM-A , OM-A-M 110V , 220V AC 1-Phase On-Off Controller , Analog Signal Output 14
 - OM-1 , OM-A , OM-A-M 24V AC/DC On-Off Controller , Analog Signal Output 15
 - OM-1 , OM-A , OM-A-M 24V DC Modulating Controller 16
 - OM-1 , OM-A , OM-A-M 24V AC Modulating Controller 17
 - OM-1 , OM-A , OM-A-M 110V , 220V AC 1-Phase Modulating Controller 18
 - OM-1 , OM-A , OM-A-M 24V AC Modulating Controller , MODBUS 19
 - OM-1 , OM-A , OM-A-M 24V DC Modulating Controller , MODBUS 20
 - OM-1 , OM-A , OM-A-M 110V , 220V AC 1-Phase Modulating Controller , MODBUS 21
 - OM-2 ~ OM-6 12V DC On-Off Controller 22
 - OM-2 ~ OM-12 , OM-F , OM-G 24V DC On-Off Controller 22
 - OM-2 ~ OM-6 12V AC On-Off Controller 23
 - OM-2 ~ OM-12 , OM-F , OM-G 24V AC On-Off Controller 23
 - OM-7 ~ OM-10 12V DC On-Off Controller 24
 - BM-2 , OM-2 ~ OM-13 , OM-F , OM-G 110V , 220V AC 1-Phase On-Off Controller 25
 - OM-2 ~ OM-13 , OM-F , OM-G 110V , 220V AC 1-Phase On-Off Controller , Coupling Board 26
 - BM-2 , OM-2 ~ OM-13 220V , 380V , 440V AC 3-Phase On-Off Controller 27
 - OM-2 ~ OM-8 110V , 220V AC 1-Phase On-Off Controller , 75% duty cycle 28
 - OM-9 ~ OM-13 110V AC 1-Phase On-Off Controller , 50% duty cycle 29
 - OM-9 ~ OM-13 220V AC 1-Phase On-Off Controller , 50% duty cycle 30
 - OM-2 ~ OM-13 110V , 220V AC 1-Phase On-Off Controller , Analog Signal Output 31
 - OM-2 ~ OM-13 220V , 380V , 440V AC 3-Phase On-Off Controller , Analog Signal Output 32
 - OM-2 ~ OM-6 12V DC Modulating Controller 33
 - OM-2 ~ OM-12 , OM-F , OM-G 24V DC Modulating Controller 33

OM-2 ~ OM-12 , OM-F , OM-G 24V AC Modulating Controller34

OM-2 ~ OM-8 , OM-F , OM-G 110V , 220V AC 1-Phase Modulating Controller35

OM-2 ~ OM-13 220V , 380V , 440V AC 3-Phase Modulating Controller.....36

OM-2 ~ OM-8 110V , 220V AC 1-Phase Modulating Controller , 75% duty cycle37

OM-9 ~ OM-13 110V AC 1-Phase Modulating Controller , 50% duty cycle38

OM-9 ~ OM-13 220V AC 1-Phase Modulating Controller , 50% duty cycle39

OM-2 ~ OM-13 110V , 220V AC 1-Phase On-Off Controller , Local Control Unit40

OM-2 ~ OM-13 220V , 380V , 440V AC 3-Phase On-off Controller , Local Control Unit.....41

OM-2 ~ OM-8 110V , 220V AC 1-Phase Modulating Controller , Local Control Unit.....42

OM-2 ~ OM-8 110V , 220V AC 1-Phase Modulating Controller , Local Control Unit , 75% duty cycle43

OM-9 ~ OM-13 110V AC 1-Phase Modulating Controller , Local Control Unit , 50% duty cycle44

OM-9 ~ OM-13 220V AC 1-Phase Modulating Controller , Local Control Unit , 50% duty cycle45

OM-2 ~ OM-13 110V , 220V AC 1-Phase On-off Controller , Local Control Unit , Analog Signal Output46

OM-2 ~ OM-13 220V , 380V , 440V AC 3-Phase On-off Controller , Local Control Unit , Analog Signal Output ..47

BM-2, OM-A, OM-A-M, OM-1~OM-13, OM-F,OM-G 110V,220V AC 1-Phase Same Switch CouplingWiring...48

ADJUSTMENT – Travel Cam & Limit Switches49

ADJUSTMENT – Mechanical Stops52

ADJUSTMENT – Modulating Control Board53

 Part A: Suitable for OM-1~OM-13 、 OM-A 、 OM-A-M 、 OM-F 、 OM-G53

 Part B: Suitable for OM-1 、 OM-A 、 OM-A-M (MODBUS optional).....59

TROUBLE SHOOTING.....71

WARRANTY73

OVERVIEW

Sun Yeh electric quarter-turn actuators offer a range of 35N·m to 4500N·m torque. Product design is based on a self-locking worm drive principal, which provides for a smooth running, dependable, robust drive system. All models are ISO 5211 compliant, have a visual position indicator on top of actuator cover and manual override except BM-2 and OMA. The manual operation is **non-clutch** design that can be operated without any lever, clutch or brake upon power outage. This design has already won the new Patent in Taiwan, U.S.A. and China.

Features

- ✓ 30% duty cycle at rated torque.
- ✓ Self-locking function.
- ✓ Built-in thermal protection prevents motor burning out. AC motor is 125°C (257°F) and 90°C (194°F) for DC motor. (The 75% duty cycle actuator uses DC motor.)

Model	Max. Torque		Weight		Manual Override
	N·m	lb·in	Kg	lb	
OM-A	50	443	3	6.61	N/A
OM-A-M	50	443	3	6.61	Lever
OM-1	35	310	2	4.41	
BM-2	120	1063	5.5	12.13	N/A
OM-F	65	576	11	24.25	Hand-wheel
OM-2	90	797	11	24.25	
OM-G	90	797	11	24.25	
OM-3	150	1328	11	24.25	
OM-4	400	3542	20	44.09	
OM-5	500	4427	20	44.09	
OM-6	650	5756	20	44.09	
OM-7	1000	8855	32	70.55	
OM-8	1500	13282	32	70.55	
OM-9	2000	17709	71	156.53	
OM-10	2500	22137	71	156.53	
OM-11	3000	26564	72	158.73	
OM-12	3500	30991	72	158.73	
OM-13	4500	39846	106	233.69	

IMPORTANT NOTICES



CAUTION !

For the 3-Phase on-off controller actuator, please use the hand-wheel to turn the actuator to 45 degree before test.
 ** If the direction is opposite after supplying power, please change any two of the U, V, W.

1. Check for correct voltage prior to wiring.
2. Turn power off before servicing or for maintenance purpose.
3. Use sealant to seal conduit connections after wiring to prevent dusting or water contamination.
4. The angle of electrical actuator installation must be between 0~180 degree. Do not install upside down or below the horizontal. The conduit entries can not face up.
5. When more than one electric actuator needed to operate simultaneously, please connect with the individual cables or install the coupling board.
6. Not intended for vacuum spaces and avoid installing near explosive atmospheres.
7. Actuators should be placed at clean and dry place for storage, and protected with outer carton from being affected by great temperature difference or serious vibration.
8. To avoid functional failure caused by statics, do not touch any components on the PCB with metal tools or bare hands.
9. Please connect the ground wire to PE inside the electric actuator.
10. The warranty period of our products is one year.

Duty Cycle – compliance to IEC standard

"Duty cycle" means the starting frequency.

The formula: $\text{Running Time} \div (\text{Running time} + \text{Rest Time}) \times 100\% = \text{duty cycle}$
 $\text{Rest Time} = \text{Running Time} \times (1 - \text{duty cycle}) \div \text{duty cycle}$

For example : The running time for OM-2 is 15 sec.
 30% duty cycle $15 \times [(1 - 30\%) / 30\%] = 35$ → The rest time will be 35 sec.
 75% duty cycle $15 \times [(1 - 75\%) / 75\%] = 5$ → The rest time will be 5 sec.

If the duty cycle is higher, the rest time will be shortened. It means the starting frequency will be higher.

STANDARD MOUNTING

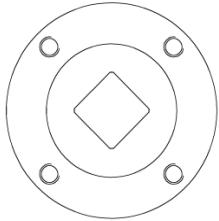
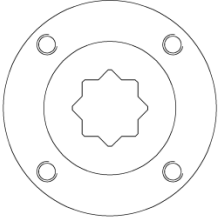
Model	Mounting Flange (ISO 5211)	Shaft		Depth of shaft		Key	
		mm	inch	mm	inch	mm	inch
BM-2		F07	22	0.87	30	1.18	N/A
OM-A		F05 / F07	17	0.67	20	0.78	N/A
OM-A-M		F05 / F07	17	0.67	20	0.78	N/A
OM-1		F03 / F05	14	0.55	17	0.67	N/A
OM-F, OM-G		F07	22	0.87	30	1.18	N/A
OM-2~OM-3		F07	22	0.87	30	1.18	N/A
OM-4~OM-6		F10	36	1.38	40	1.57	N/A
OM-7~OM-8		F12 or F14	35	1.38	60	2.36	10 x10
OM-9~OM-12	F14 or F16	75	2.95	100	3.94	12 x10	0.47x0.39
OM-13	F16 / F25	72	2.83	110	4.33	20 x12	0.79x0.47

SPECIFICATION

12V/24V

Model No.	Max Torque		Speed (90°)	Motor Power	12V DC/AC			24V DC/AC		
	Nm	lb-in			Run	Start	Lock	Run	Start	Lock
BM-2	-	-	-	-	-	-	-	-	-	-
OM-A	50	443	20s	10W	1.3A	1.5A	2.8A	0.8A	0.9A	1.6A
OM-A-M	50	443	20s	10W	1.3A	1.5A	2.8A	0.8A	0.9A	1.6A
OM-1	35	310	15s	10W	1.9A	2.0A	2.8A	1.1A	1.1A	1.6A
OM-2	90	797	15s	40W	3.4A	5.2A	16.5A	2.2A	4.5A	14.5A
OM-F	65	576	6s	60W	-	-	-	2.6A	3.8A	11.0A
OM-3	150	1328	22s	40W	4.4A	4.9A	16.5A	2.4A	5.0A	14.5A
OM-G	120	1063	8s	60W	-	-	-	4.4A	4.8A	11.0A
OM-4	400	3542	16s	80W	16.1A	16.1A	33.0A	8.5A	9.2A	30.0A
OM-5	500	4427	22s	80W	14.1A	13.5A	33.0A	7.5A	9.0A	30.0A
OM-6	650	5756	28s	80W	12.3A	12.5A	33.0A	7.0A	8.5A	30.0A
OM-7	1000	8855	46s	80W				6.8A	7.8A	30.0A
OM-8	1500	13282	46s	80W				25A	26A	59A
OM-9	2000	17709	58s	80W				8.8A	11.0A	26.0A
OM-10	2500	22137	58s	80W				28A	60A	59A
OM-11	3000	26564	58s	220W				15.1A	11.0A	33.0A
OM-12	3500	30991	58s	220W				17.8A	12.0A	33.0A

Single Phase

Model No.	Max Torque		Speed (90°)		Motor Power	110V Current			220V-240V Current		
	Nm	lb-in	60 Hz	50 Hz		Run	Start	Lock	Run	Start	Lock
BM-2	120	1063	8s	10s	40W	1.3A	1.6A	1.6A	0.6A	0.9A	0.9A
OM-A	50	443	20s	24s	10W	0.6A	0.6A	0.7A	0.3A	0.4A	0.5A
OM-A-M	50	443	20s	24s	10W	0.6A	0.6A	0.7A	0.3A	0.4A	0.5A
OM-1	35	310	12s	13s	10W	0.6A	0.6A	0.7A	0.3A	0.4A	0.4A
OM-2	90	797	15s	17s	40W	1.0A	1.8A	1.6A	0.5A	0.8A	0.9A
OM-F	65	576	6s	6s	60W	1.4A	2.1A	3.1A	0.7A	1.0A	1.5A
OM-3	150	1328	22s	26s	40W	1.2A	1.8A	1.6A	1.0A	1.2A	0.9A
OM-G	120	1063	8s	8s	60W	1.6A	3.0A	3.1A	0.8A	1.2A	1.5A
OM-4	400	3542	16s	18s	80W	1.9A	3.8A	3.6A	1.1A	2.0A	2.2A
OM-5	500	4427	22s	25s	80W	2.0A	3.8A	3.6A	1.1A	2.0A	2.2A
OM-6	650	5756	28s	31s	80W	2.1A	3.8A	3.6A	1.1A	2.0A	2.2A
OM-7	1000	8855	46s	55s	120W	3.1A	8.5A	9.0A	1.4A	4.1A	5.0A
OM-8	1500	13282	46s	55s	120W	3.3A	9.0A	9.0A	1.6A	4.4A	5.0A
OM-9	2000	17709	58s	70s	180W	3.3A	5.8A	5.9A	2.1A	3.8A	3.6A
OM-10	2500	22137	58s	70s	180W	4.0A	6.5A	5.9A	2.3A	4.0A	3.6A
OM-11	3000	26564	58s	70s	180W	4.5A	3.5A	5.9A	2.5A	4.2A	3.6A
OM-12	3500	30991	58s	70s	220W	4.0A	8.0A	7.5A	2.4A	4.4A	4.8A
OM-13	4500	39846	80s	95s	220W	4.2A	8.0A	7.5A	2.4A	4.8A	4.8A

SPECIFICATION

Three Phase

Model No.	Max Torque		Speed (90°)		Motor Power	220V Current			380V Current			440V Current		
	Nm	lb-in	60Hz	50Hz		Run	Start	Lock	Run	Start	Lock	Run	Start	Lock
BM-2	120	1063	8 s	10 s	40W	0.8A	1.4A	1.5A	0.4A	0.9A	0.7A	0.4A	0.5A	0.6A
OM-1	-	-	-	-	-	-	-	-	-	-	-	-	-	-
OM-A	-	-	-	-	-	-	-	-	-	-	-	-	-	-
OM-A-M	-	-	-	-	-	-	-	-	-	-	-	-	-	-
OM-2	90	797	15s	17s	40W	0.8A	1.4A	1.5A	0.4A	0.7A	0.7A	0.4A	0.9A	0.6A
OM-3	150	1328	22s	26s	40W	0.8A	1.4A	1.5A	0.4A	0.7A	0.7A	0.4A	0.9A	0.6A
OM-4	400	3542	16s	18s	80W	1.0A	1.8A	2.3A	0.7A	1.3A	1.5A	0.6A	1.4A	1.4A
OM-5	500	4427	22s	25s	80W	1.0A	1.8A	2.3A	0.7A	1.3A	1.5A	0.6A	1.4A	1.4A
OM-6	650	5756	28s	31s	80W	1.0A	1.8A	2.3A	0.7A	1.3A	1.5A	0.6A	1.4A	1.4A
OM-7	1000	8855	46s	55s	120W	0.9A	2.0A	2.2A	0.7A	1.2A	1.4A	0.5A	1.3A	1.3A
OM-8	1500	13282	46s	55s	120W	1.0A	2.4A	2.6A	0.7A	1.5A	1.5A	0.6A	1.2A	1.2A
OM-9	2000	17709	58s	70s	180W	1.3A	3.7A	3.9A	0.7A	2.0A	2.3A	0.7A	2.0A	2.2A
OM-10	2500	22137	58s	70s	180W	1.3A	3.4A	3.9A	0.7A	2.0A	2.4A	0.7A	2.0A	2.2A
OM-11	3000	26564	58s	70s	180W	1.3A	3.5A	3.9A	0.7A	2.0A	2.4A	0.7A	2.0A	2.2A
OM-12	3500	30991	58s	70s	220W	1.5A	4.8A	5.4A	0.9A	2.5A	2.5A	0.8A	2.6A	2.4A
OM-13	4500	39846	80s	95s	220W	1.5A	4.9A	5.4A	1.0A	2.5A	2.5A	0.8A	2.6A	2.4A

NOTE :

Run : Full Load Ampere
 Lock : Locked Rotor Ampere

STORAGE INFORMATION

Receiving/Inspection

Carefully inspect for shipping damage. Damage to the shipping carton is usually a good indication that it has received rough handling. Report all damage immediately to the freight carrier and your seller.

After unpacking the product and information packet, please take care to save the shipping carton and any packing material in case of product return or replacement. Verify that the item on the packing list or bill of lading is the same as your own documentation. If there is any discrepancy, please contact with the seller.

Storage

If the actuator cannot be installed immediately, store it in a dry place, it must be protected from excess moisture, dust, and weather until you are ready to connect cables.

If the actuator has to be installed but cannot be cabled, please don't remove the plastic transit cable entry plugs. When the actuator has to be cabled, it is recommended to replace to suitable water-proof plugs with IP protection.

LUBRICATION

The gear train has been permanently lubricated at the factory sufficient.

INSTALLATION

1. Before mounting actuator, verify that the torque requirement is less than the output torque of the actuator. (The suggested safety factor is 30% of the max. torque of valve.)

For example :

If the maximum torque of 5" valve is $80\text{N}\cdot\text{m} \rightarrow 80 \times 1.3(\text{safety factor}) = 104\text{N}\cdot\text{m}$

$104\text{N}\cdot\text{m} < 150\text{N}\cdot\text{m} (\text{OM-3}) \rightarrow \text{OK!}$

$104\text{N}\cdot\text{m} > 90\text{N}\cdot\text{m} (\text{OM-2}) \rightarrow \text{NO!}$

2. Check if the output shaft fits to the stem of valve before inserting into actuator. Please use mounting plate or adaptor to connect if it does not match.
3. Insert output shaft adaptor into actuator. Make sure it fits satisfactory.
4. Determine that actuator position, open or closed, matches with position of equipment prior to mounting. Use manual override to change position if necessary.
5. Remove valve's manual device and mount on the proper connection.



CAUTION: Don't remove any necessary parts for the proper operation of the valve.

6. Check again that the valve and actuator are in the same position.
7. Install the actuator to valve directly or with mounting kits, then tighten all screws and nuts.
8. Remove actuator cover.



CAUTION: Be sure power is off at the main power box.

9. Wire actuator using the wiring diagram inside cover.



CAUTION: For the 3-Phase on-off controller actuator, please use the hand-wheel to turn the actuator to 45 degree before test. If the operating direction is opposite after supplying power, please change any two of the U, V, W.

10. Supply power to actuator.



CAUTION: Use remarkable mark warning "there are live circuits that could cause electrical shock or death".

11. Make sure if it is needed to calibrate the fully-open or fully-closed position of the actuator. Refer to the P49~P52 to set the fully -open or fully-closed position and mechanical stops.
12. If the actuator is modulating type, refer to P53~P70 to set the functions.



CAUTION: Turn power off before changing any setting.

13. Replace cover and secure cover screws.

WIRING DIAGRAM

1. MC1 & MC2 : Electromagnetic contactor.
2. NFB : No fuse breaker.
3. C.S. : Control switch.
4. C : Capacitor.
5. N : Neutral.
6. L : Live Wire.
7. PE : Protective Earth.
8. O.L. : Over-load relay.
9. H : Heater.
10. LS : Limit switch.
11. TS : Torque switch.
12. Switch(1) : Local/Remote Control.
Switch(2) : Open/Stop/Close select.
13. Duty cycle (Standard Model) :
BM-2, OM-A, OM-A-M, OM-F, OM-G, OM-1~OM-13 : 30% duty cycle.
Extended duty cycle :
OM-A, OM-A-M, OM-1~OM-8 : 75% duty cycle.
OM-9~OM-13 : 50% duty cycle.
14. LS1 : Limit switch for open.
LS2 : Limit switch for close.
15. The usage for 2 additional limit switches :
OM-1, OM-A, OM-A-M
LS3 Fully-Open : Terminal "A" connects to terminal "B".
LS4 Fully-Closed : Terminal "A" connects to terminal "E".
OM-1, OM-A, OM-A-M (Option: MODBUS)
LS3 Fully-Open : Terminal "A" connects to terminal "C".
LS4 Fully-Closed : Terminal "D" connects to terminal "F".
BM-2, OM-A, OM-AM, OM-F, OM-G, OM-2~OM-13
LS3 Fully-Open : Terminal "A" connects to terminal "C".
LS4 Fully-Closed : Terminal "D" connects to terminal "F".



NOTE !

When a set of control wire or switch needs to control two or more actuators at the same time, please refer to P48 or install the coupling board.

WIRING DIAGRAM – Quarter Turn Actuator

OM-1 , OM-A , OM-A-M 12V , 24V DC

On-Off Controller

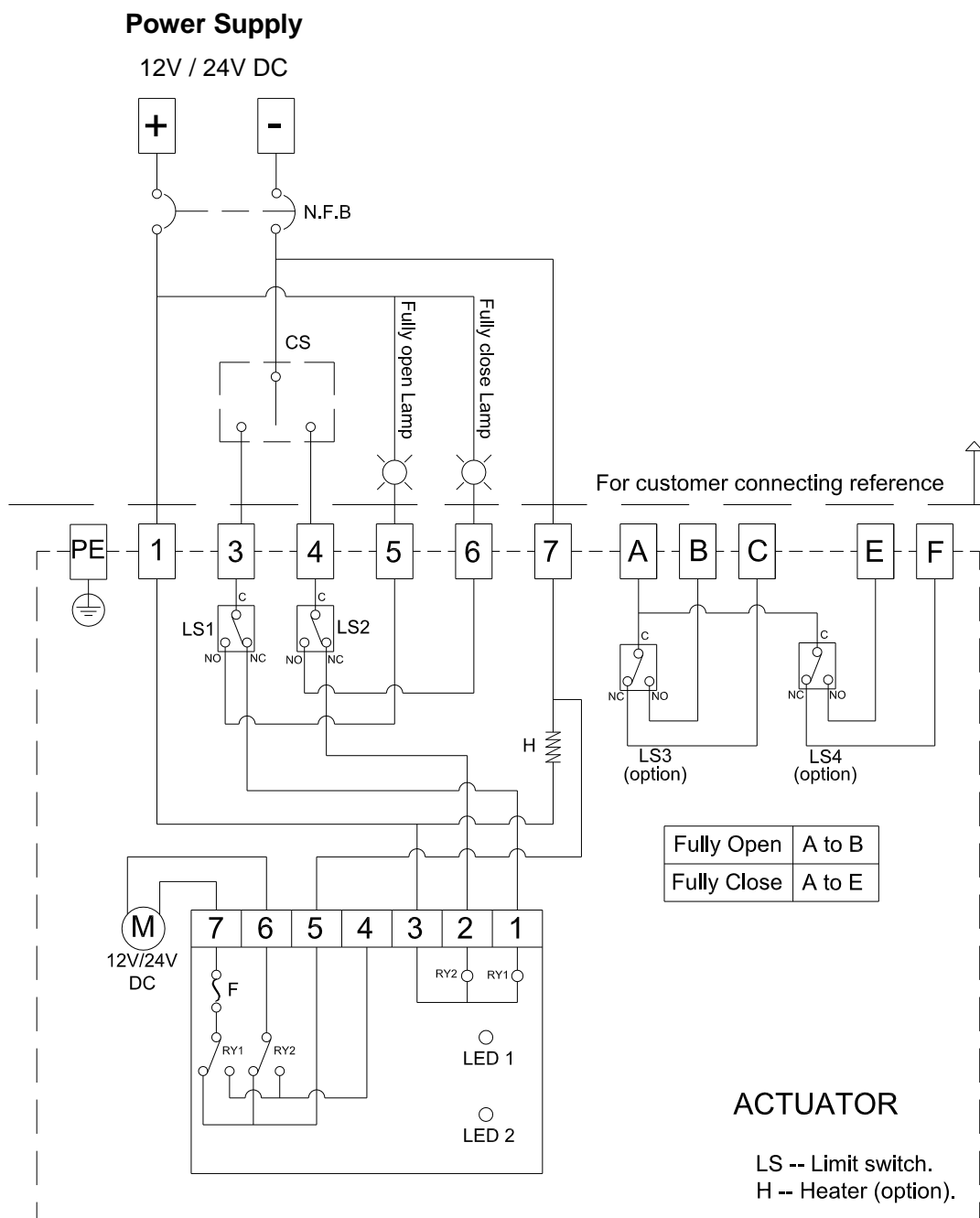

NOTE:

1. "+" connects to #1, "-" connects to #7.
2. "-" connects to #3 for "OPEN", "-" connects to #4 for "CLOSE".
3. Using less than 3A current for "A, B, C, E, F".
4. Using battery to supply power for DC units.

WIRING DIAGRAM – Quarter Turn Actuator

OM-1 , OM-A , OM-A-M 12V , 24V AC

On-Off Controller

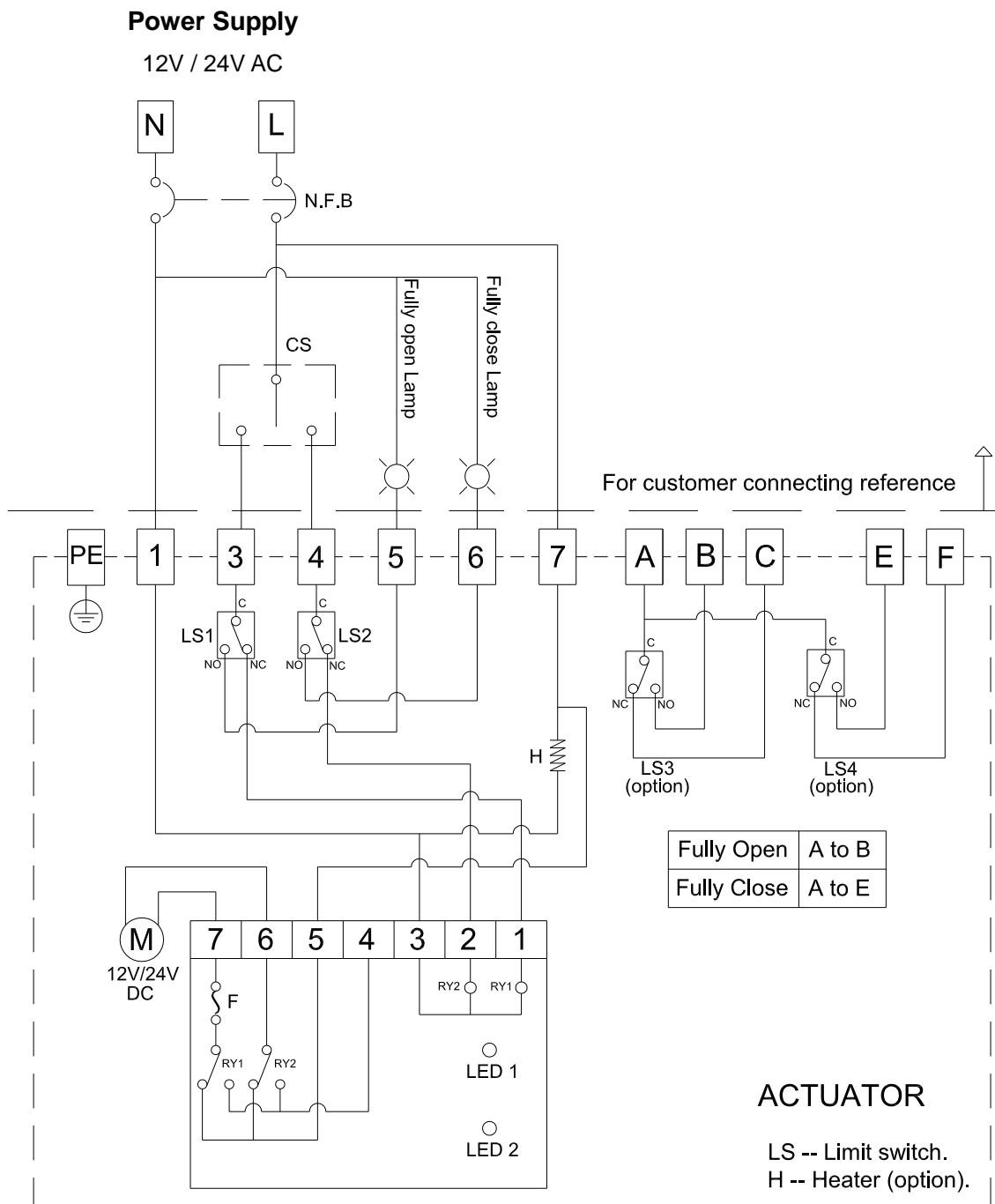

NOTE :

1. "N" connects to #1, "L" connects to #7.
2. "L" connects to #3 for "OPEN", "L" connects to #4 for "CLOSE".
3. Using less than 3A current for "A, B, C, E, F".

WIRING DIAGRAM – Quarter Turn Actuator

OM-1 , OM-A , OM-A-M 110V , 220V AC 1-Phase

On-Off Controller

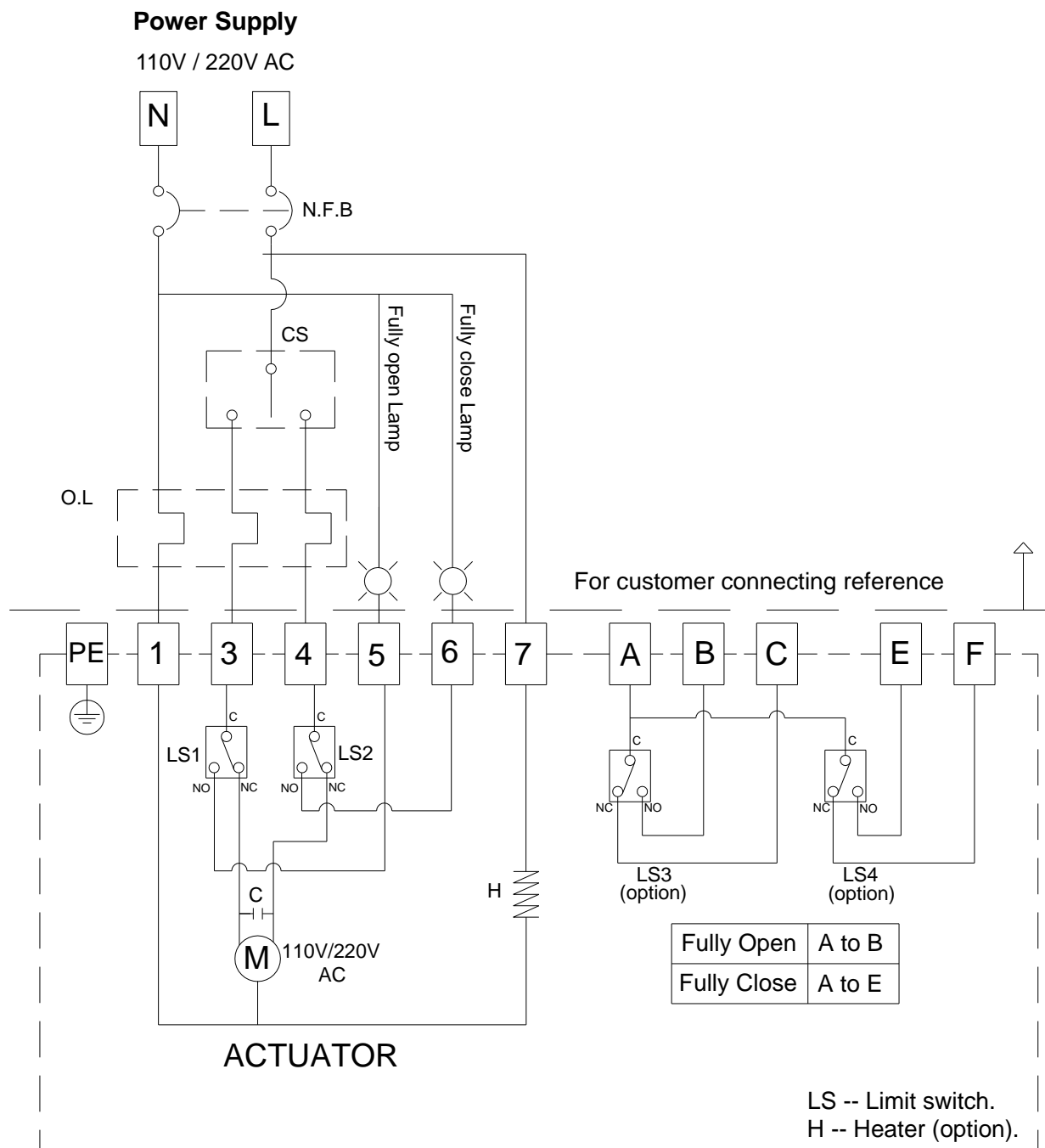

NOTE :

1. "N" connects to #1, "L" connects to #7.
2. "L" connects to #3 for "OPEN", "L" connects to #4 for "CLOSE".
3. Using less than 3A current for "A, B, C, E, F".

WIRING DIAGRAM – Quarter Turn Actuator

OM-1 , OM-A , OM-A-M 110V , 220V AC 1-Phase

On-Off Controller , 75% duty cycle

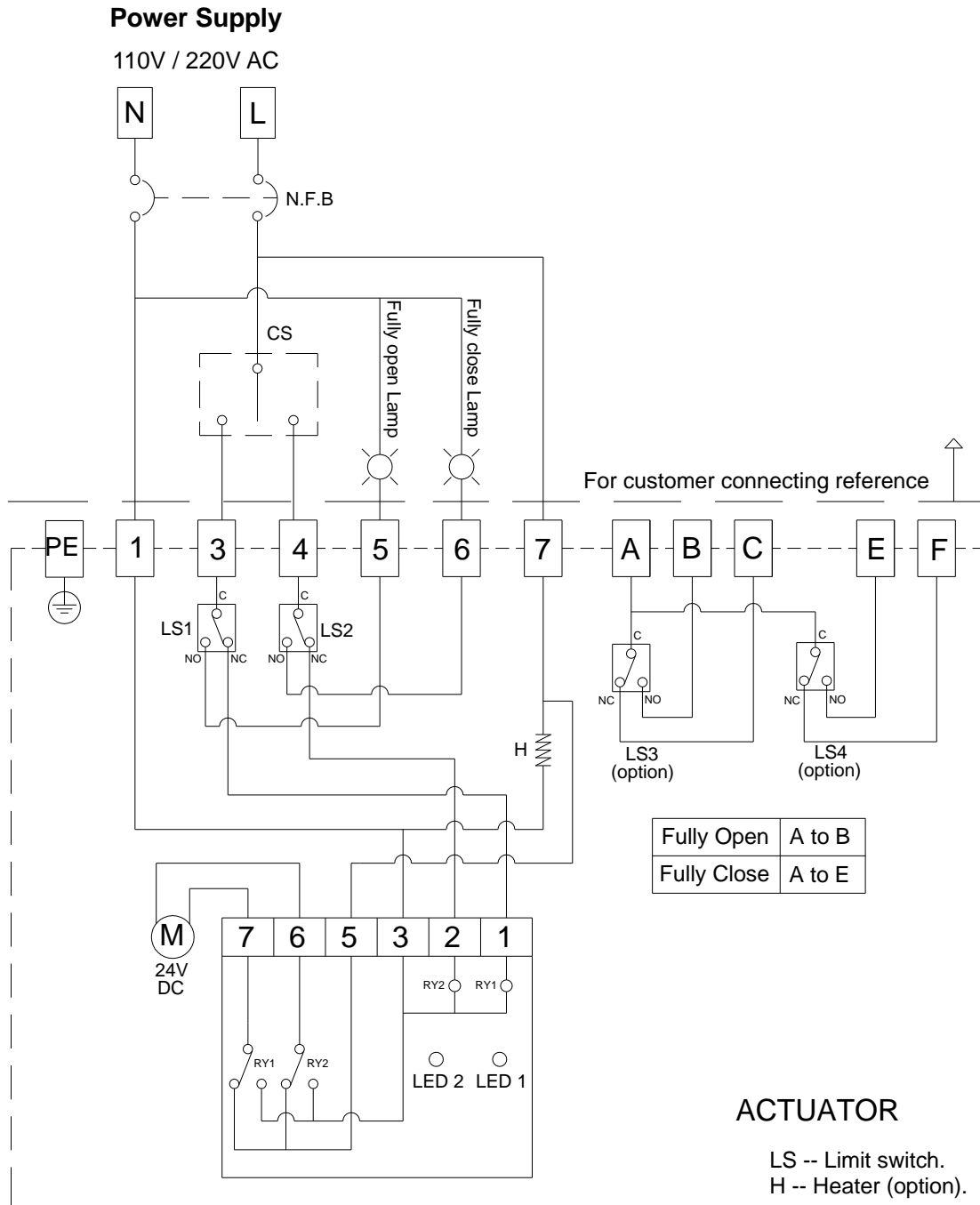

NOTE :

1. "N" connects to #1, "L" connects to #7.
2. "L" connects to #3 for "OPEN", "L" connects to #4 for "CLOSE".
3. Using less than 3A current for "A, B, C, E, F".

WIRING DIAGRAM – Quarter Turn Actuator

OM-1 , OM-A , OM-A-M 110V , 220V AC 1-Phase

On-Off Controller , Coupling Board

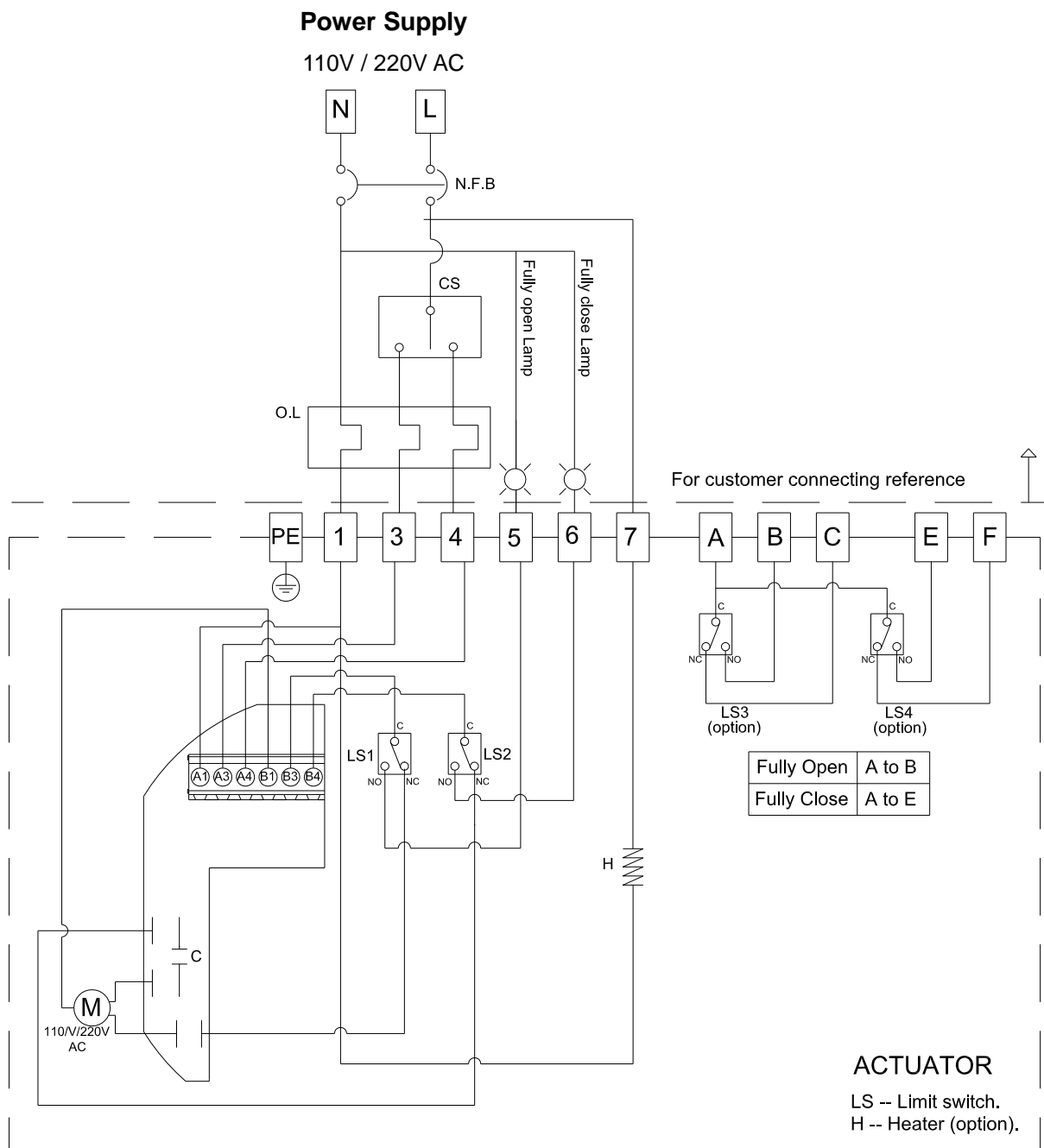

NOTE :

1. "N" connects to #1, "L" connects to #7.
2. "L" connects to #3 for "OPEN", "L" connects to #4 for "CLOSE".
3. Using less than 3A current for "A, B, C, E, F".

WIRING DIAGRAM – Quarter Turn Actuator

OM-1 , OM-A , OM-A-M 110V , 220V AC 1-Phase

On-Off Controller , Analog Signal Output

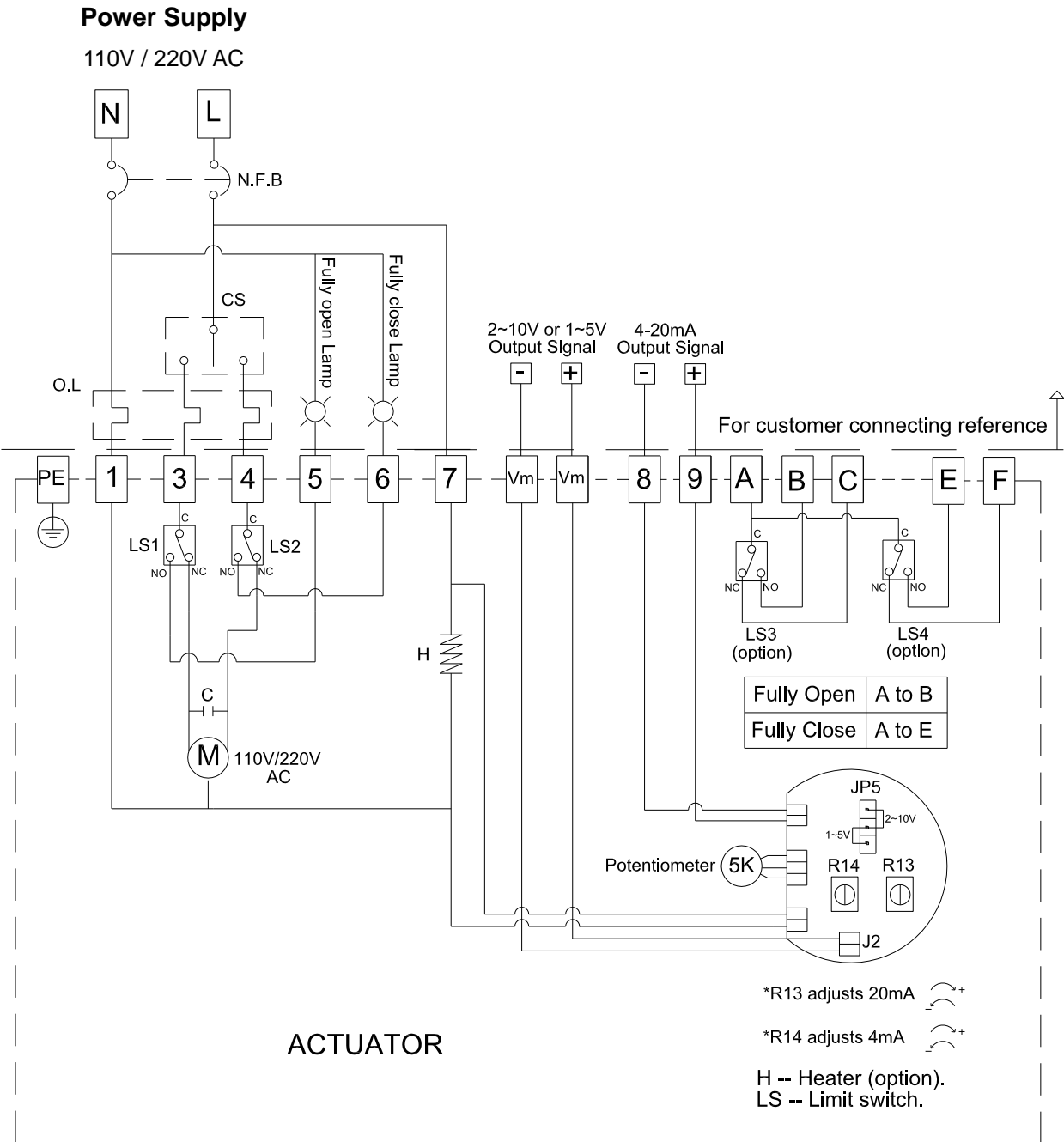

NOTE:

1. "N" connects to #1, "L" connects to #7.
2. "L" connects to #3 for "OPEN", "-" connects to #4 for "CLOSE".
3. Using less than 3A current for "A, B, C, E, F".
4. JP5 : 2~10V or 1~5V output mode ; J2 : 2~10V or 1~5V output signal.

WIRING DIAGRAM – Quarter Turn Actuator

OM-1 , OM-A , OM-A-M 24V AC/DC

On-Off Controller , Analog Signal Output

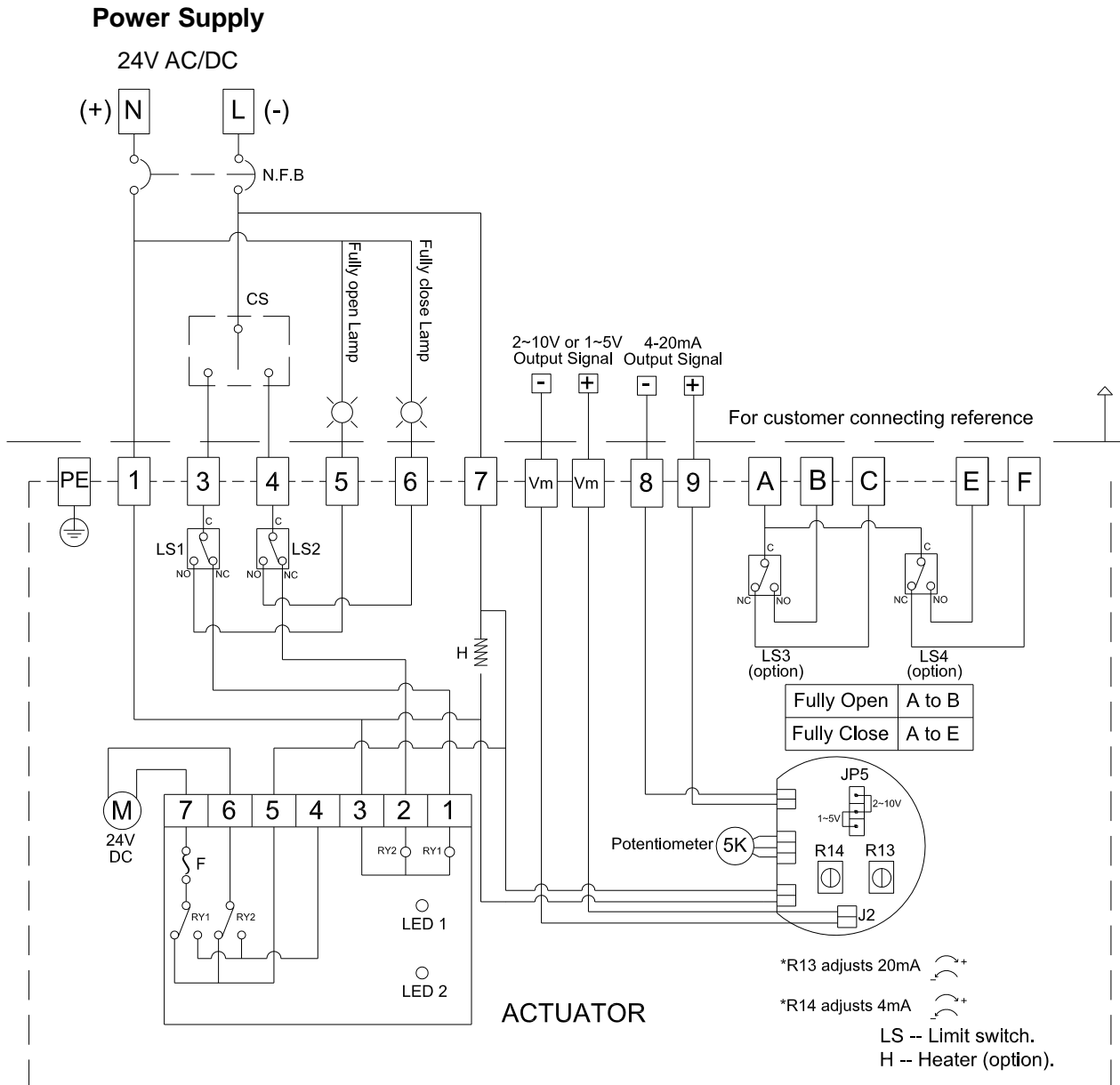

NOTE:

1. "N" connects to #1, "L" connects to #7.
2. "L" connects to #3 for "OPEN", "-" connects to #4 for "CLOSE".
3. Using less than 3A current for "A, B, C, E, F".
4. JP5 : 2~10V or 1~5V output mode ; J2 : 2~10V or 1~5V output signal.

WIRING DIAGRAM – Quarter Turn Actuator

OM-1 , OM-A , OM-A-M 24V DC

Modulating Controller

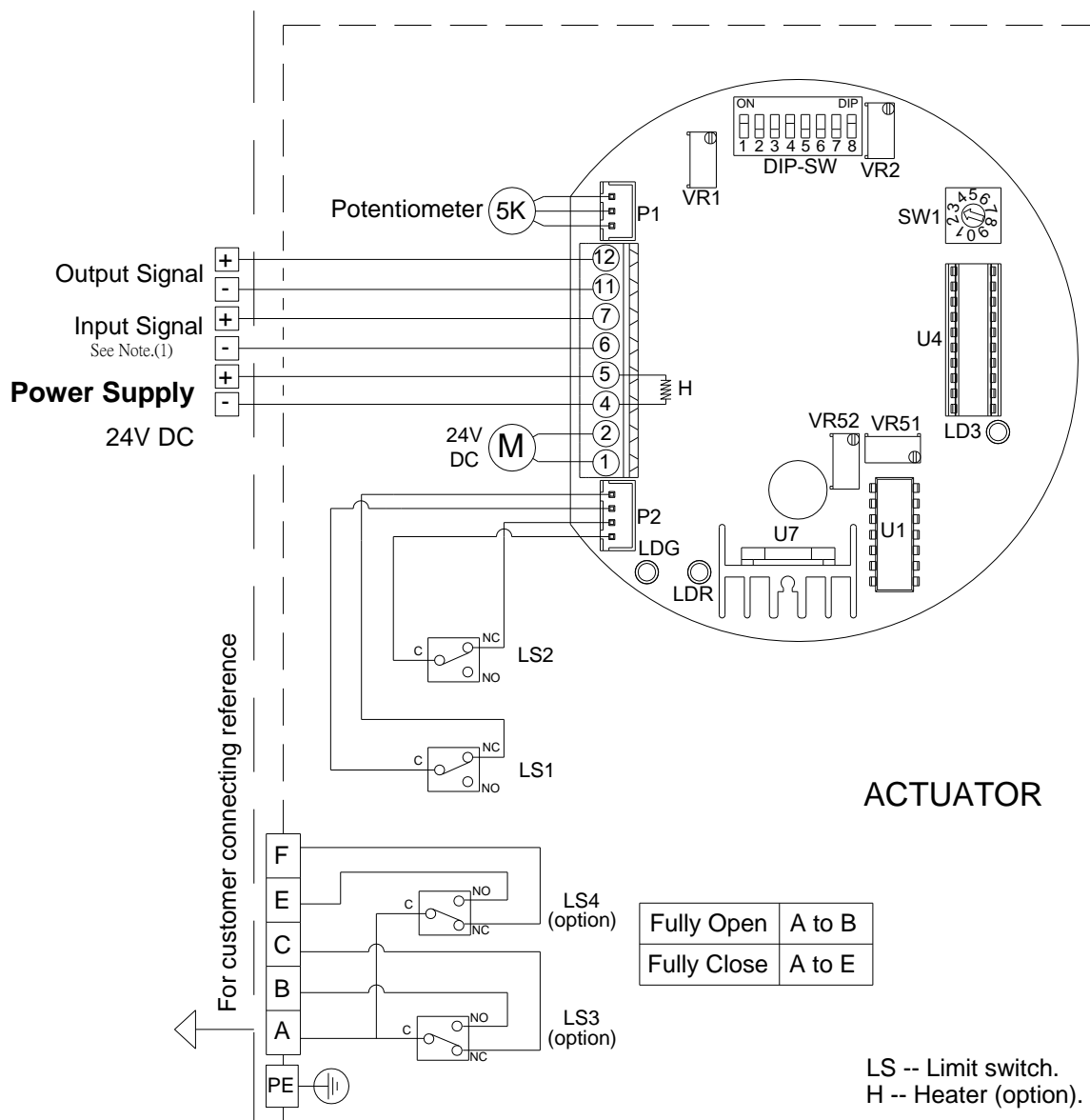

NOTE :

- Modulating Board**
 - Input Signal : 4~20mA, 1~5V, 2~10V
(It is suggested to use the shielding wire and its length should not exceed 30m.)
 - Output Signal : 4~20mA, 2~10V
- Using less than 3A current for "A, B, C, E, F".
- Using battery to supply power for DC units.

WIRING DIAGRAM – Quarter Turn Actuator

OM-1 , OM-A , OM-A-M 24V AC

Modulating Controller

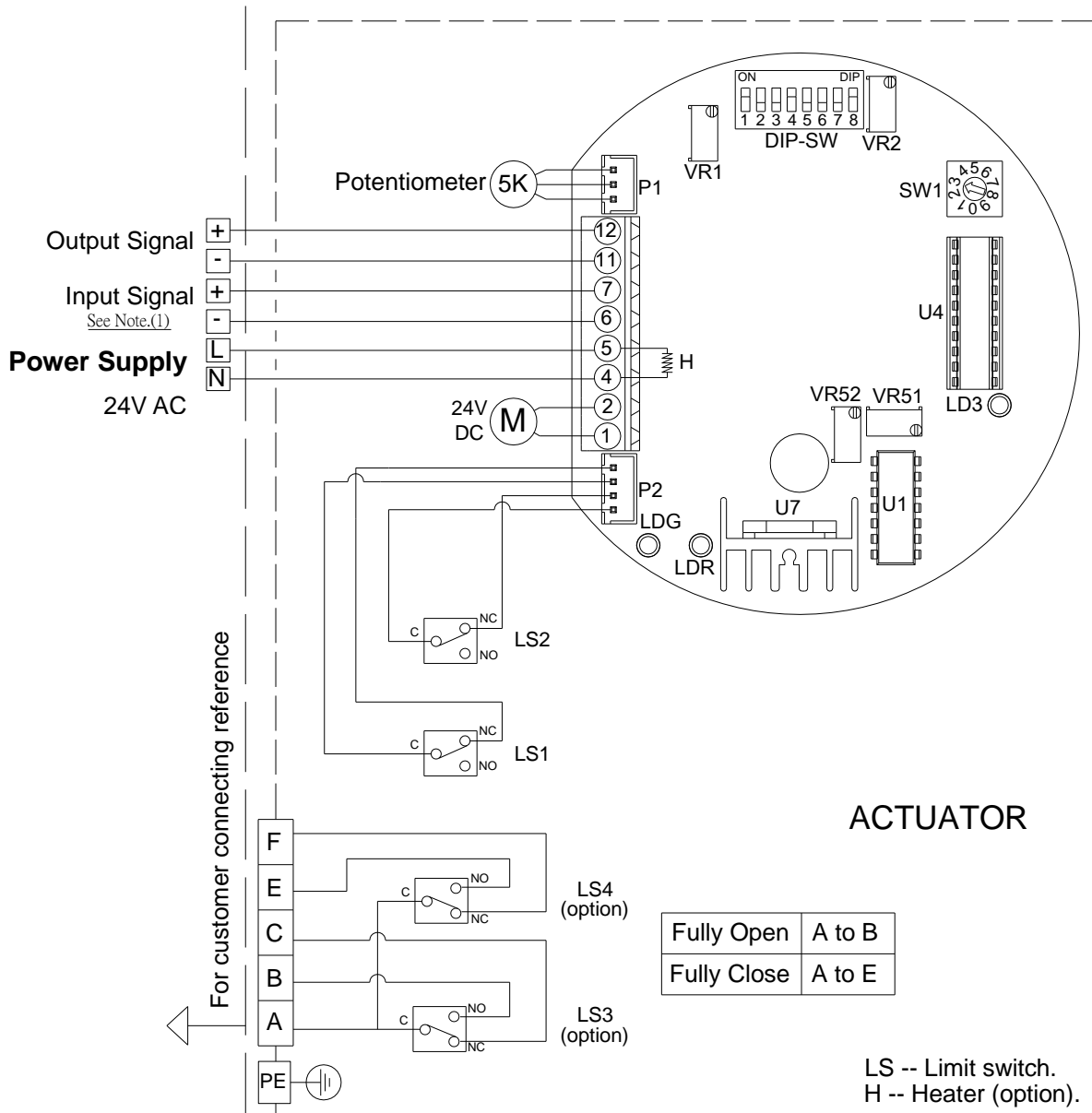

NOTE :

1. **Modulating Board**
 - a. Input Signal : 4~20mA, 1~5V, 2~10V
(It is suggested to use the shielding wire and its length should not exceed 30m.)
 - b. Output Signal : 4~20mA, 2~10V
2. Using less than 3A current for "A, B, C, E, F".

WIRING DIAGRAM – Quarter Turn Actuator

OM-1 , OM-A , OM-A-M 110V , 220V AC 1-Phase

Modulating Controller

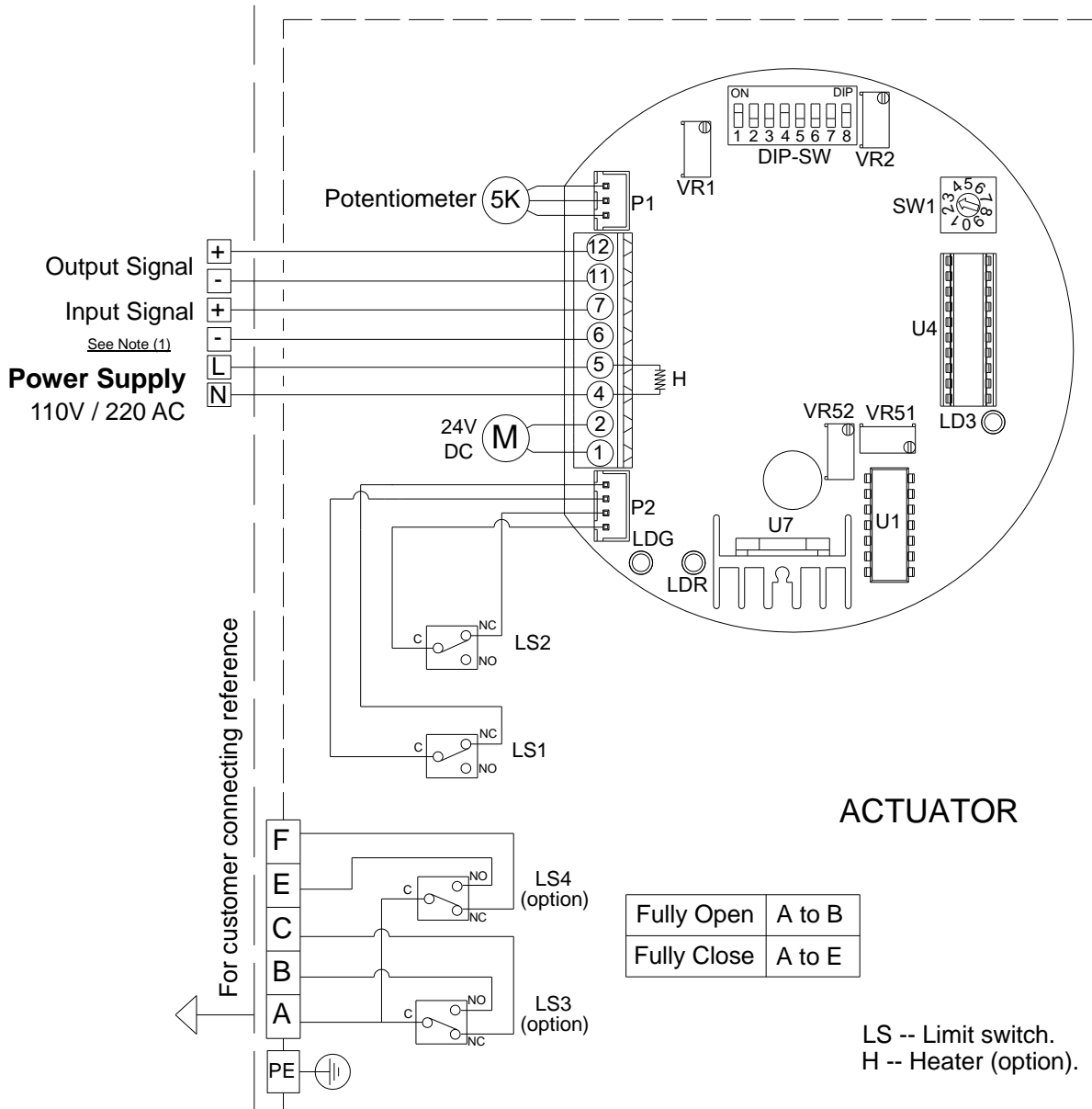

NOTE:

1. Modulating Board

- a. Input Signal : 4~20mA, 1~5V, 2~10V
(It is suggested to use the shielding wire and its length should not exceed 30m.)
- b. Output Signal : 4~20mA, 2~10V

- 2. Using less than 3A current for "A, B, C, E, F".

WIRING DIAGRAM – Quarter Turn Actuator

OM-1 , OM-A , OM-A-M 24V AC

Modulating Controller , MODBUS

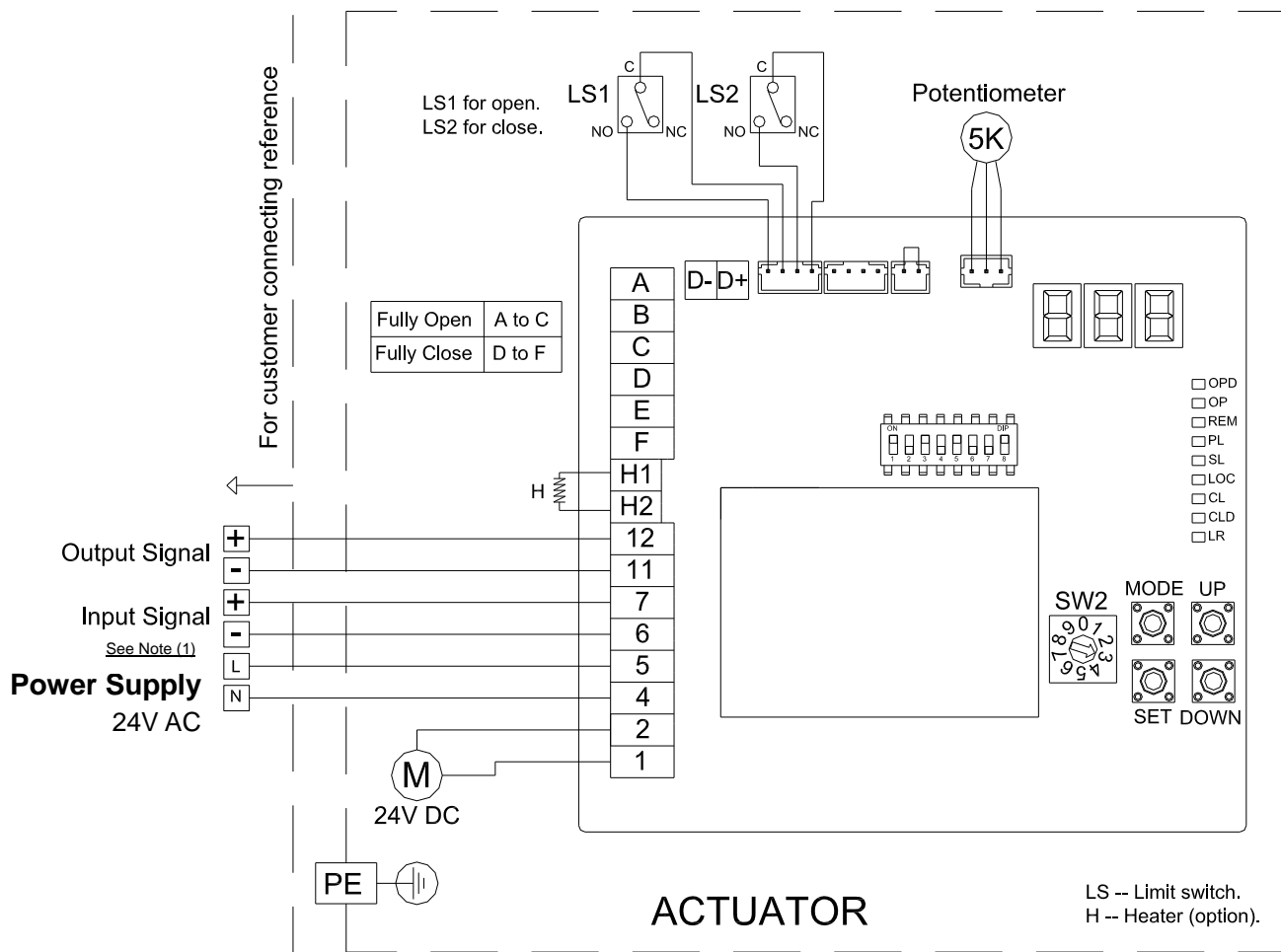

NOTE:

1. Modulating Board

- a. Input Signal : 4~20mA, 1~5V, 2~10V
(It is suggested to use the shielding wire and its length should not exceed 30m.)
- b. Output Signal : 4~20mA, 2~10V

- 2. Using less than 3A current for "A, B, C, E, F".

WIRING DIAGRAM – Quarter Turn Actuator

OM-1 , OM-A , OM-A-M 24V DC

Modulating Controller , MODBUS

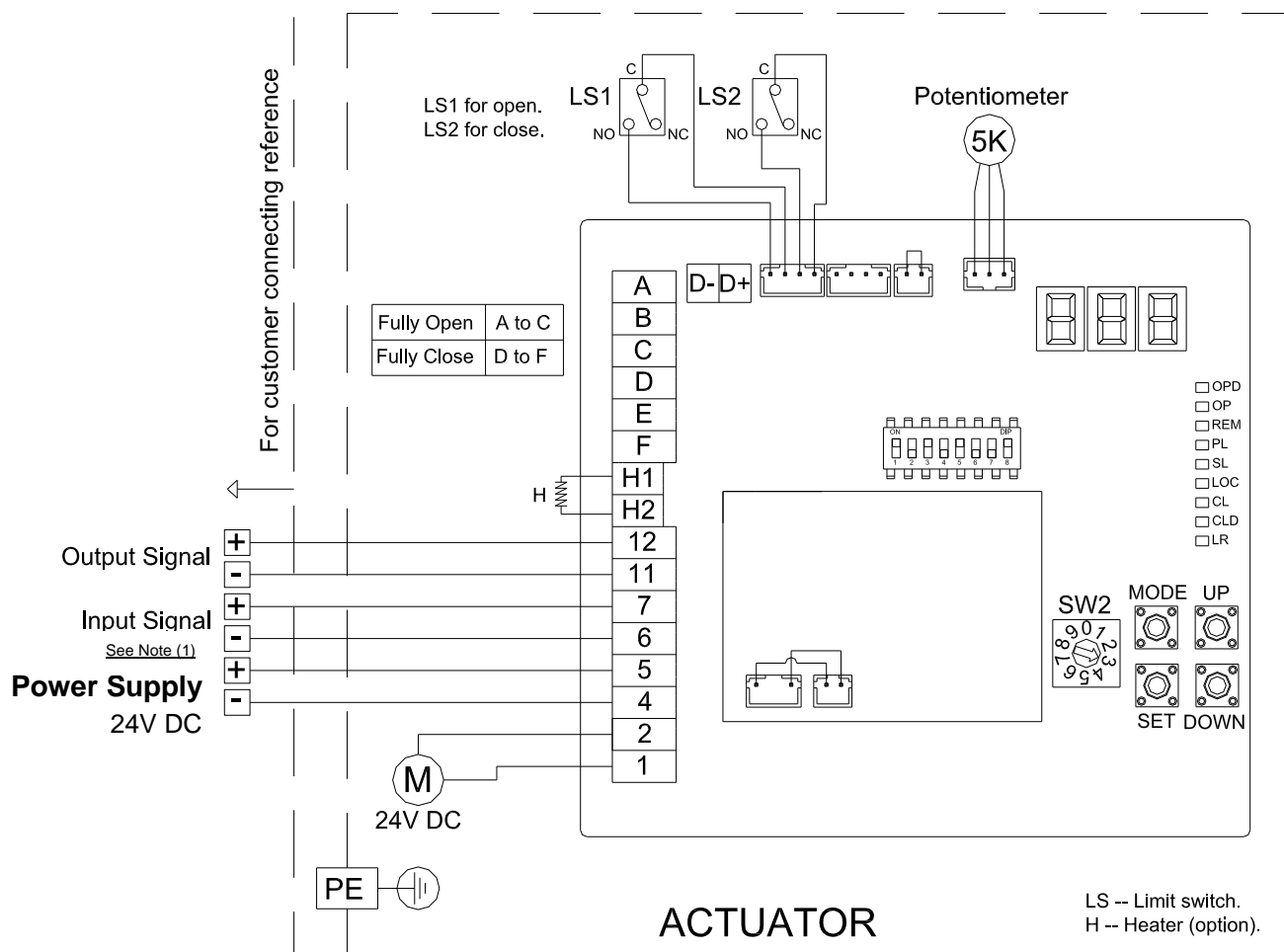

NOTE :

1. Modulating Board

a. Input Signal : 4~20mA, 1~5V, 2~10V

(It is suggested to use the shielding wire and its length should not exceed 30m.)

b. Output Signal : 4~20mA, 2~10V

2. Using less than 3A current for "A, B, C, E, F".

3. Using battery to supply power for DC units.

WIRING DIAGRAM – Quarter Turn Actuator

OM-1 , OM-A , OM-A-M 110V , 220V AC 1-Phase

Modulating Controller , MODBUS

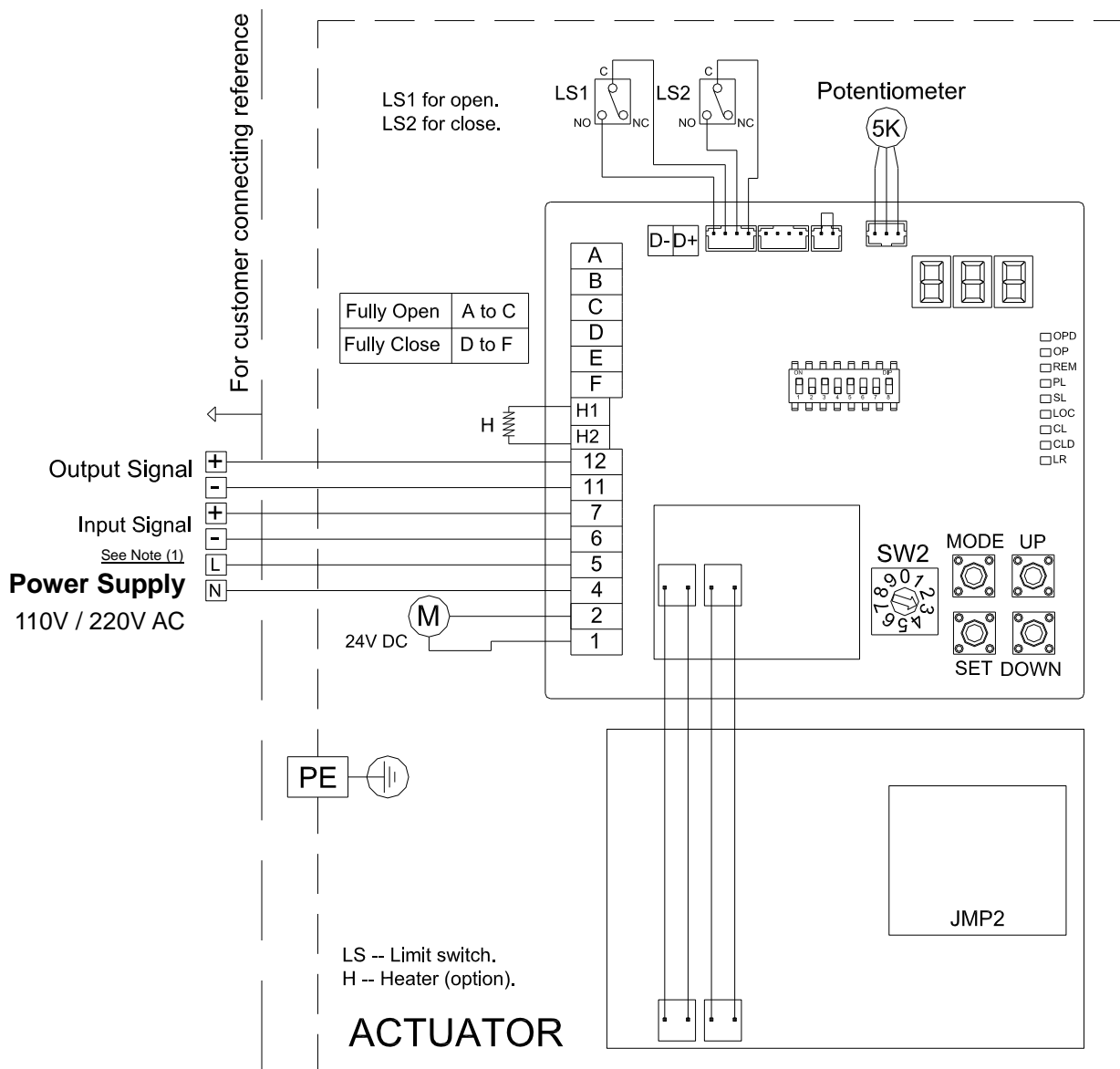

NOTE:

1. **Modulating Board**
 - a. Input Signal : 4~20mA, 1~5V, 2~10V
(It is suggested to use the shielding wire and its length should not exceed 30m.)
 - b. Output Signal : 4~20mA, 2~10V
2. Using less than 3A current for "A, B, C, E, F".

WIRING DIAGRAM – Quarter Turn Actuator

OM-2 ~ OM-6 12V DC

OM-2 ~ OM-12 , OM-F , OM-G 24V DC

On-Off Controller

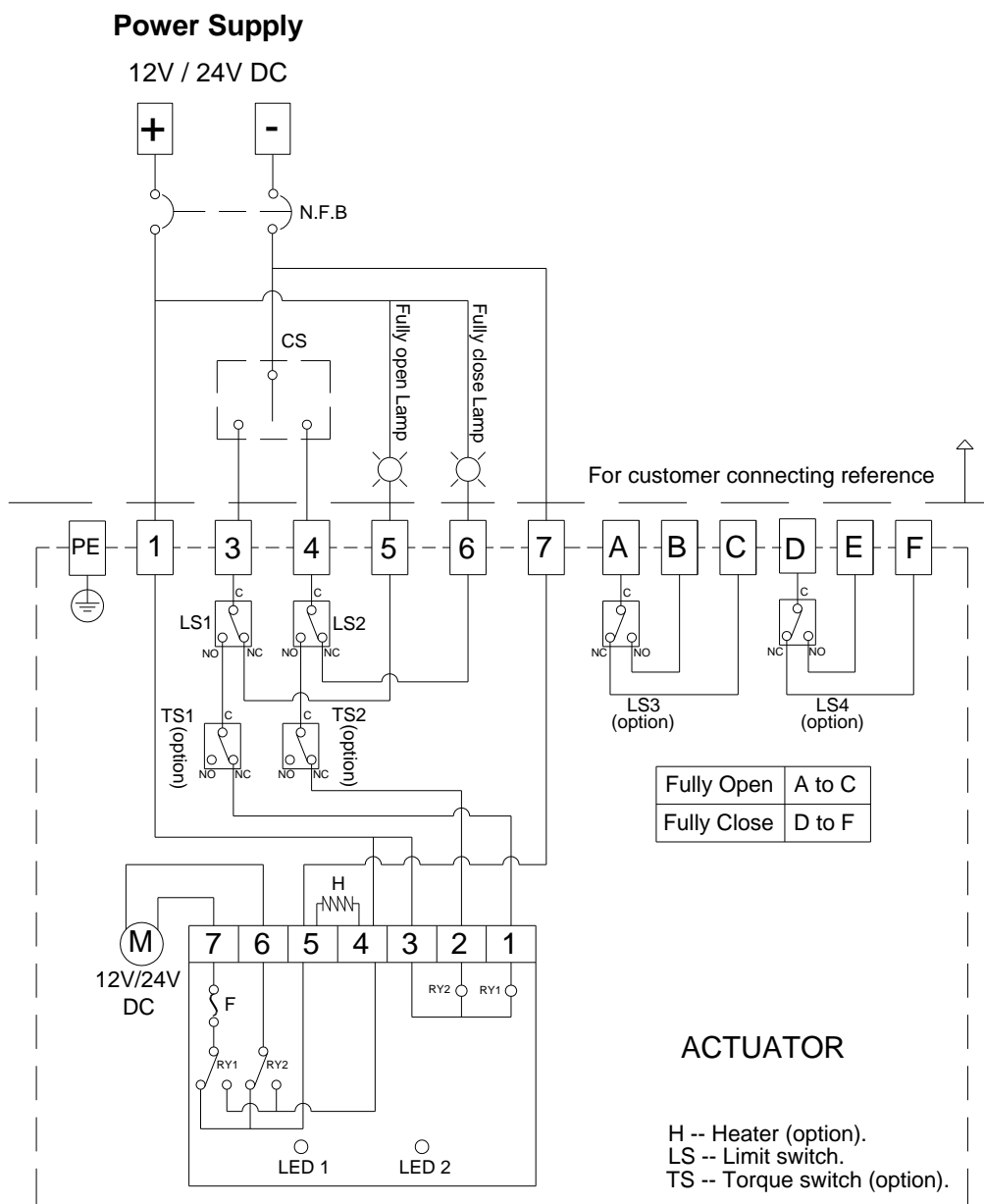

NOTE:

1. "+" connects to #1, "-" connects to #7.
2. "-" connects to #3 for "OPEN", "-" connects to #4 for "CLOSE".
3. Using less than 5A current for "A, B, C, D, E, F".
4. Using battery to supply power for DC units.

WIRING DIAGRAM – Quarter Turn Actuator

OM-2 ~ OM-6 12V AC

OM-2 ~ OM-12 , OM-F , OM-G 24V AC

On-Off Controller

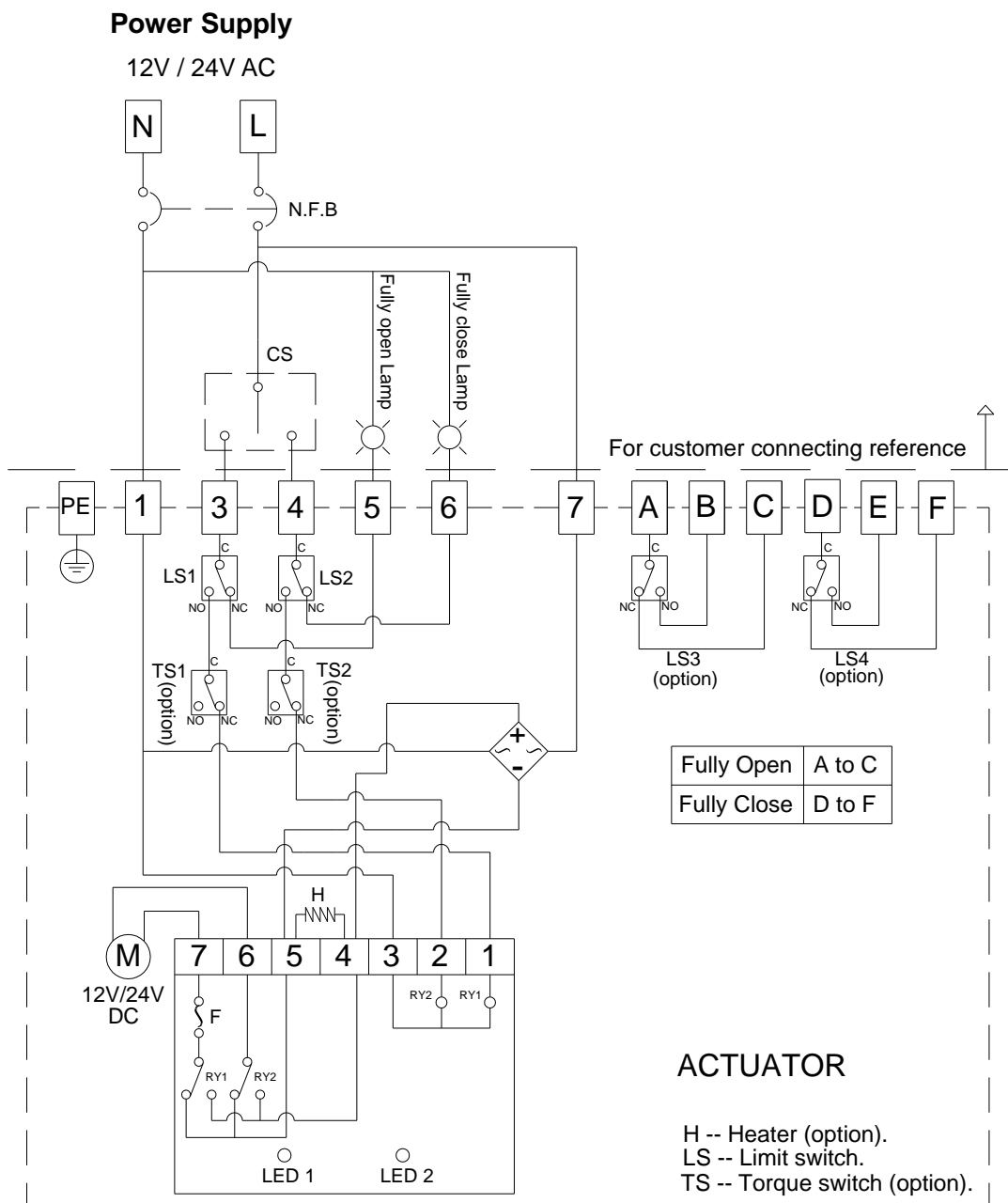

NOTE :

1. "N" connects to #1, "L" connects to #7.
2. "L" connects to #3 for "OPEN", "L" connects to #4 for "CLOSE".
3. Using less than 5A current for "A, B, C, D, E, F".

WIRING DIAGRAM – Quarter Turn Actuator

OM-7 ~ OM-10 12V DC

On-Off Controller

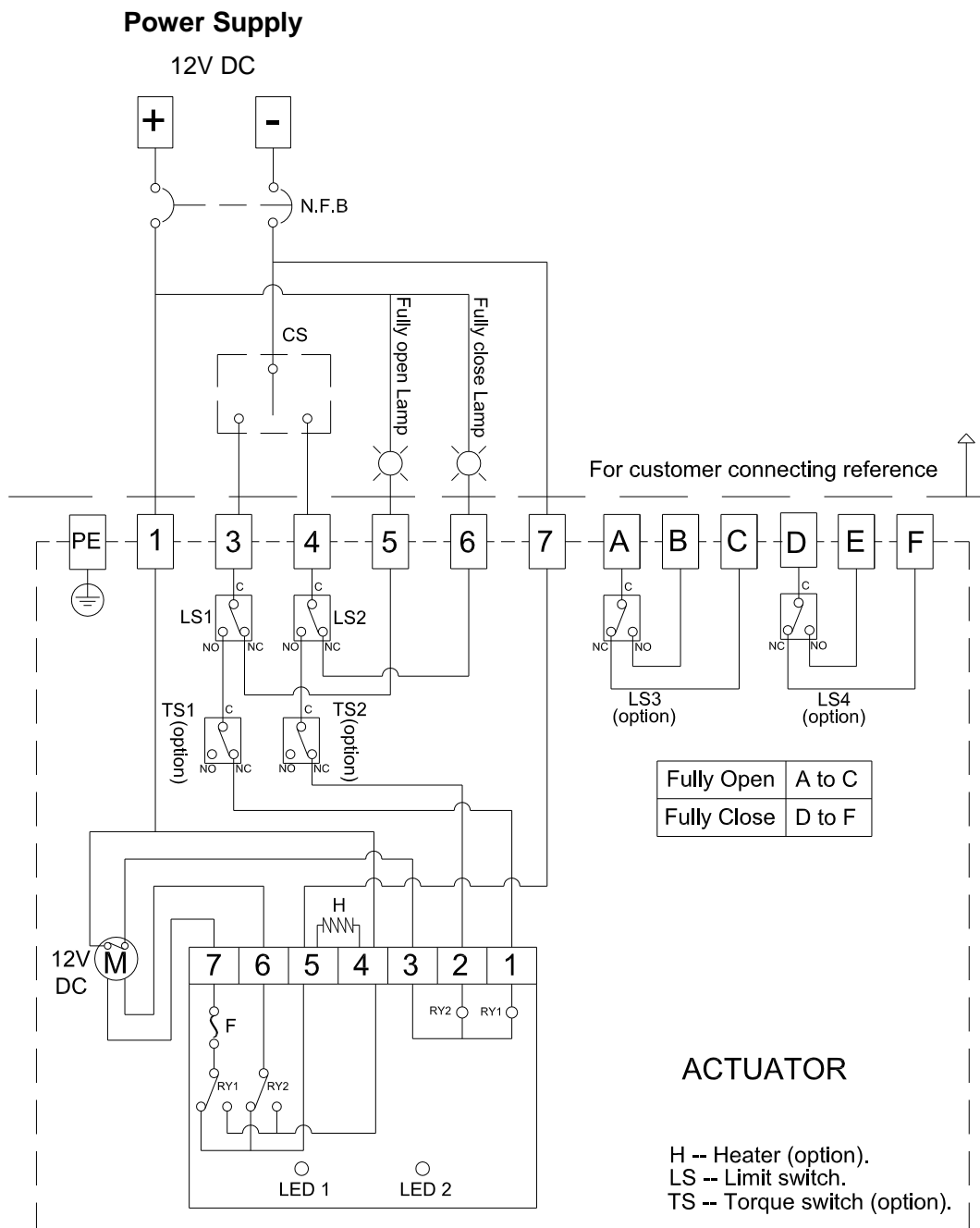

NOTE:

1. “+” connects to #1, “-” connects to #7.
2. “-” connects to #3 for “OPEN”, “-” connects to #4 for “CLOSE”.
3. Using less than 5A current for “A, B, C, D, E, F”.
4. Using battery to supply power for DC units.

WIRING DIAGRAM – Quarter Turn Actuator

BM-2 , OM-2~OM-13 , OM-F , OM-G 110V , 220V AC 1-Phase

On-Off Controller

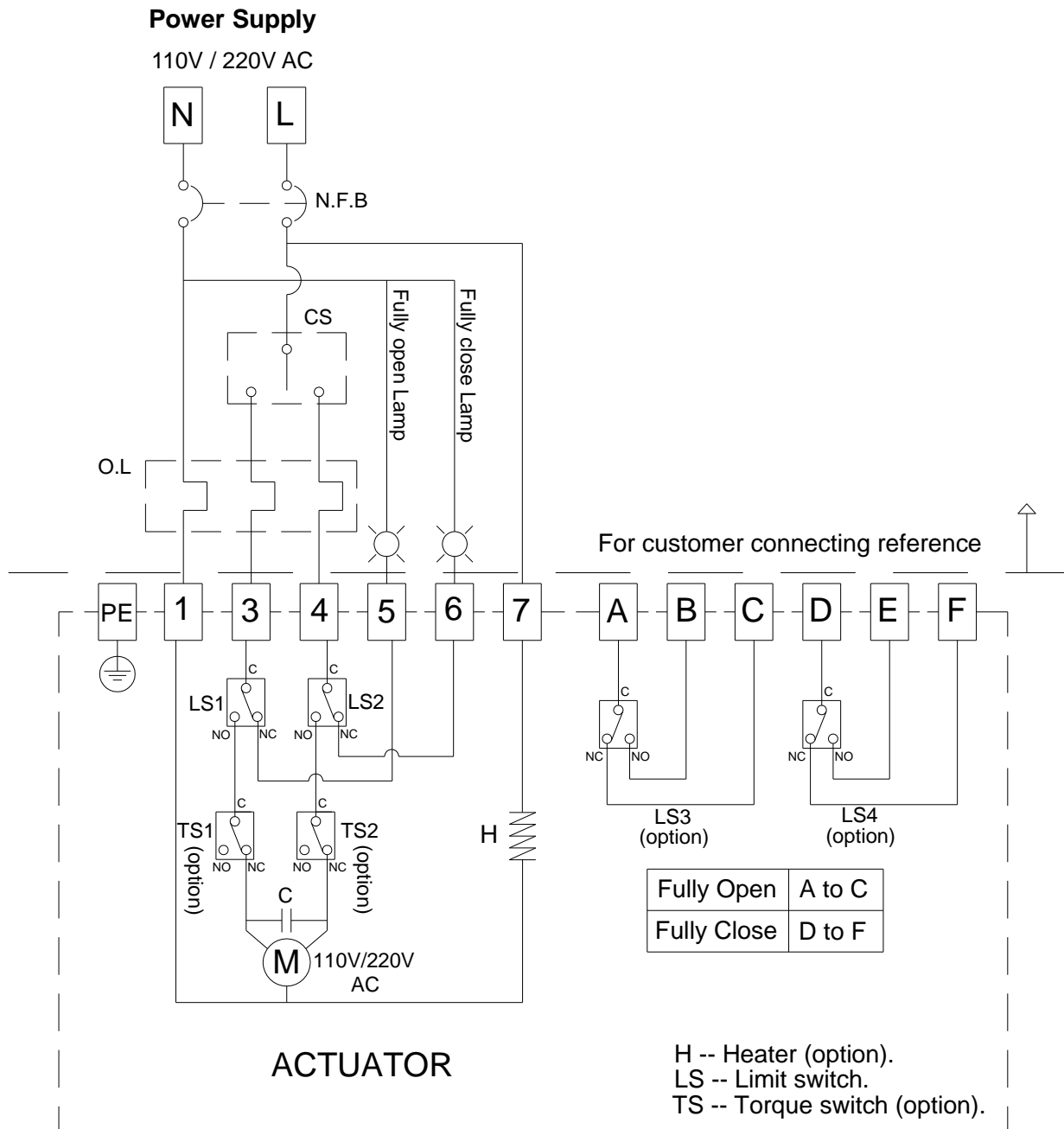

NOTE :

1. "N" connects to #1, "L" connects to #7.
2. "L" connects to #3 for "OPEN", "L" connects to #4 for "CLOSE".
3. Using less than 5A current for "A, B, C, D, E, F".
4. BM-2 could not install torque switches.

WIRING DIAGRAM – Quarter Turn Actuator

OM-2 ~ OM-13 , OM-F , OM-G 110V , 220V AC 1-Phase

On-Off Controller , Coupling Board

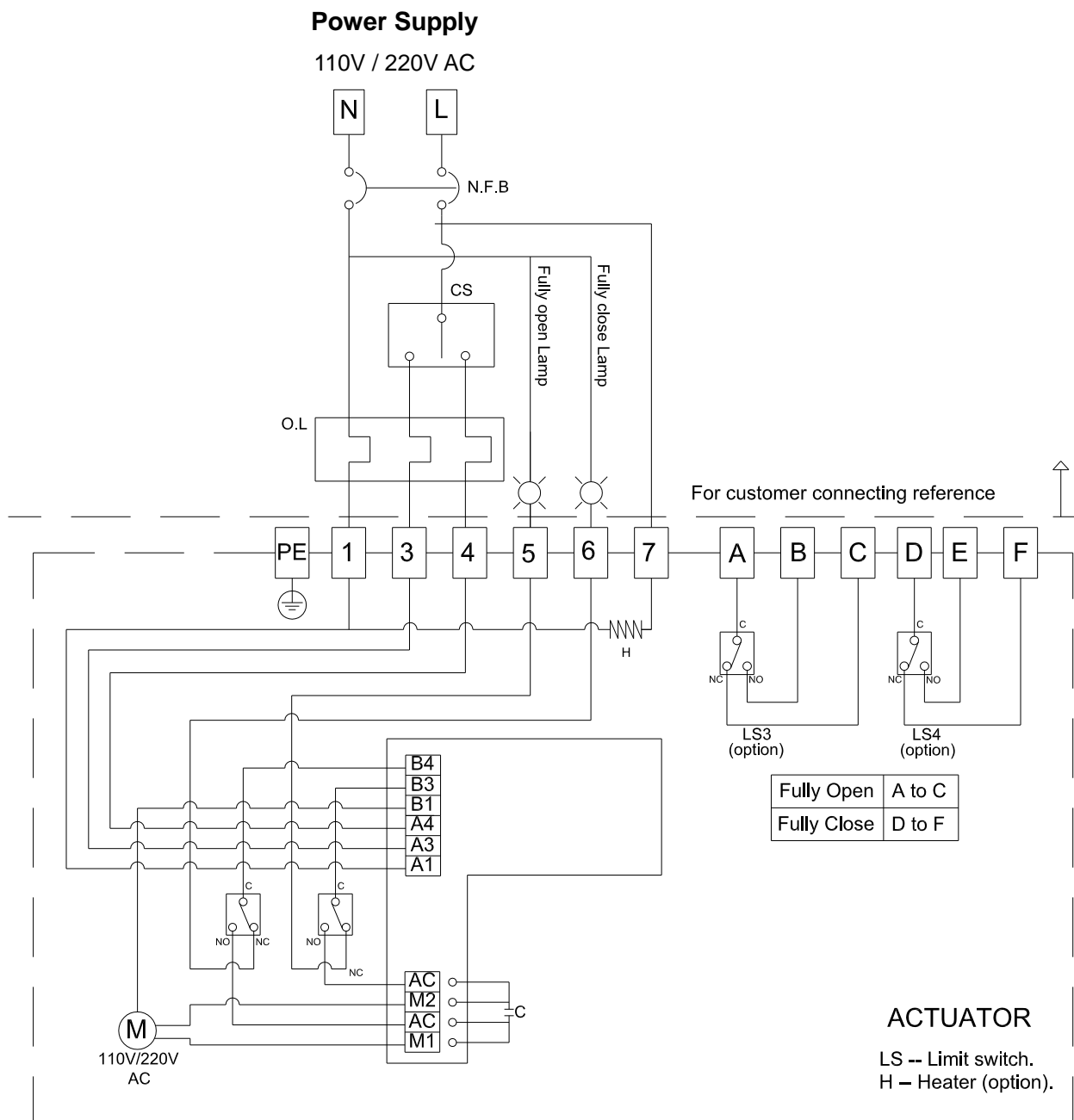

NOTE :

1. "N" connects to #1, "L" connects to #7.
2. "L" connects to #3 for "OPEN", "L" connects to #4 for "CLOSE".
3. Using less than 5A current for "A, B, C, D, E, F".

WIRING DIAGRAM – Quarter Turn Actuator

BM-2 , OM-2 ~ OM-13 220V , 380V , 440V AC 3-Phase

On-Off Controller

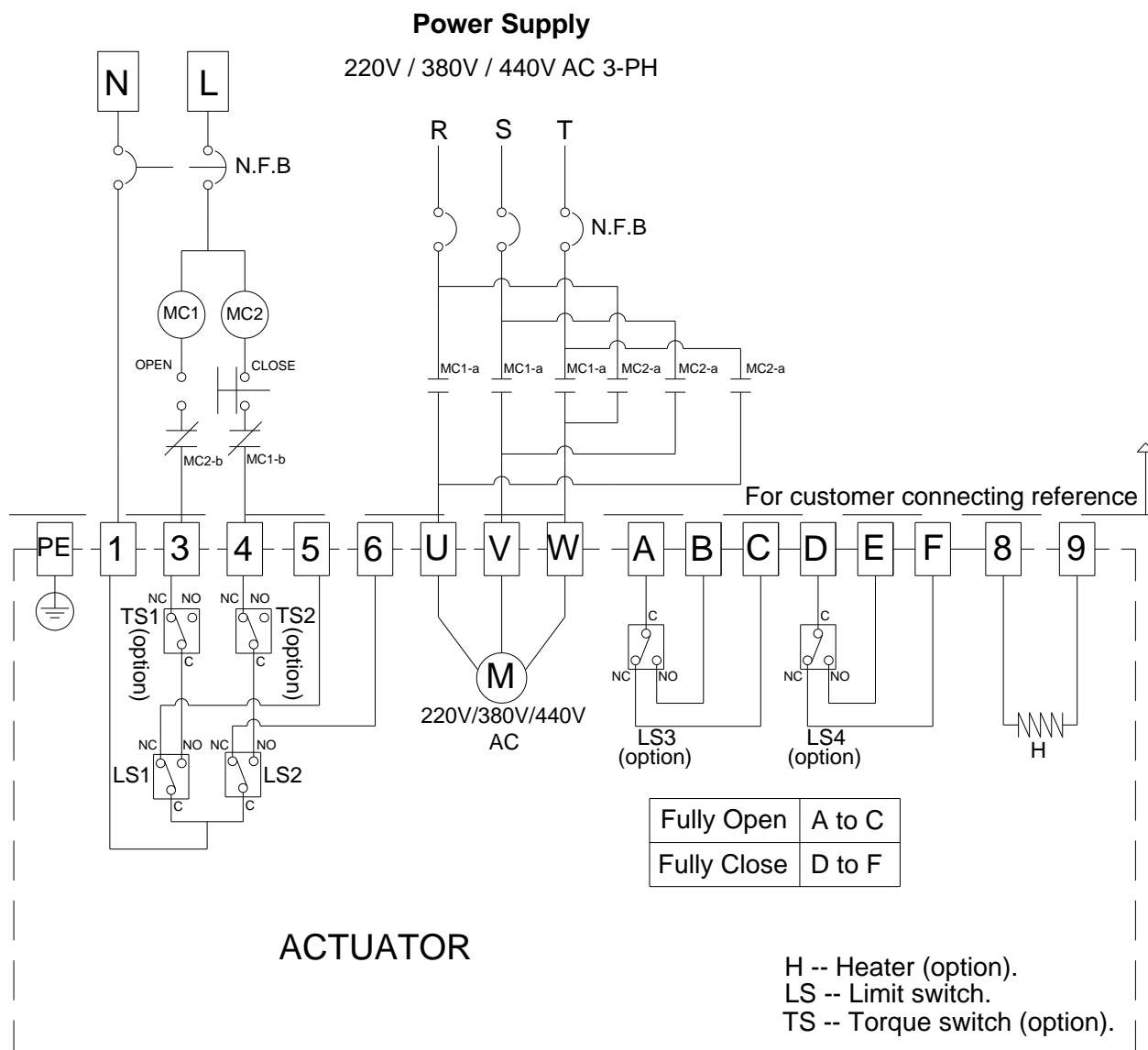

NOTE :

1. Using the hand-wheel to turn the actuator to 45 degree before test.
If the operating direction is opposite after supplying power, please change any two of the U, V, W.
2. Using less than 5A current for "A, B, C, D, E, F".
3. BM-2 could not install torque switches.

WIRING DIAGRAM – Quarter Turn Actuator

OM-2 ~ OM-8 110V , 220V AC 1-Phase

On-Off Controller , 75% duty cycle

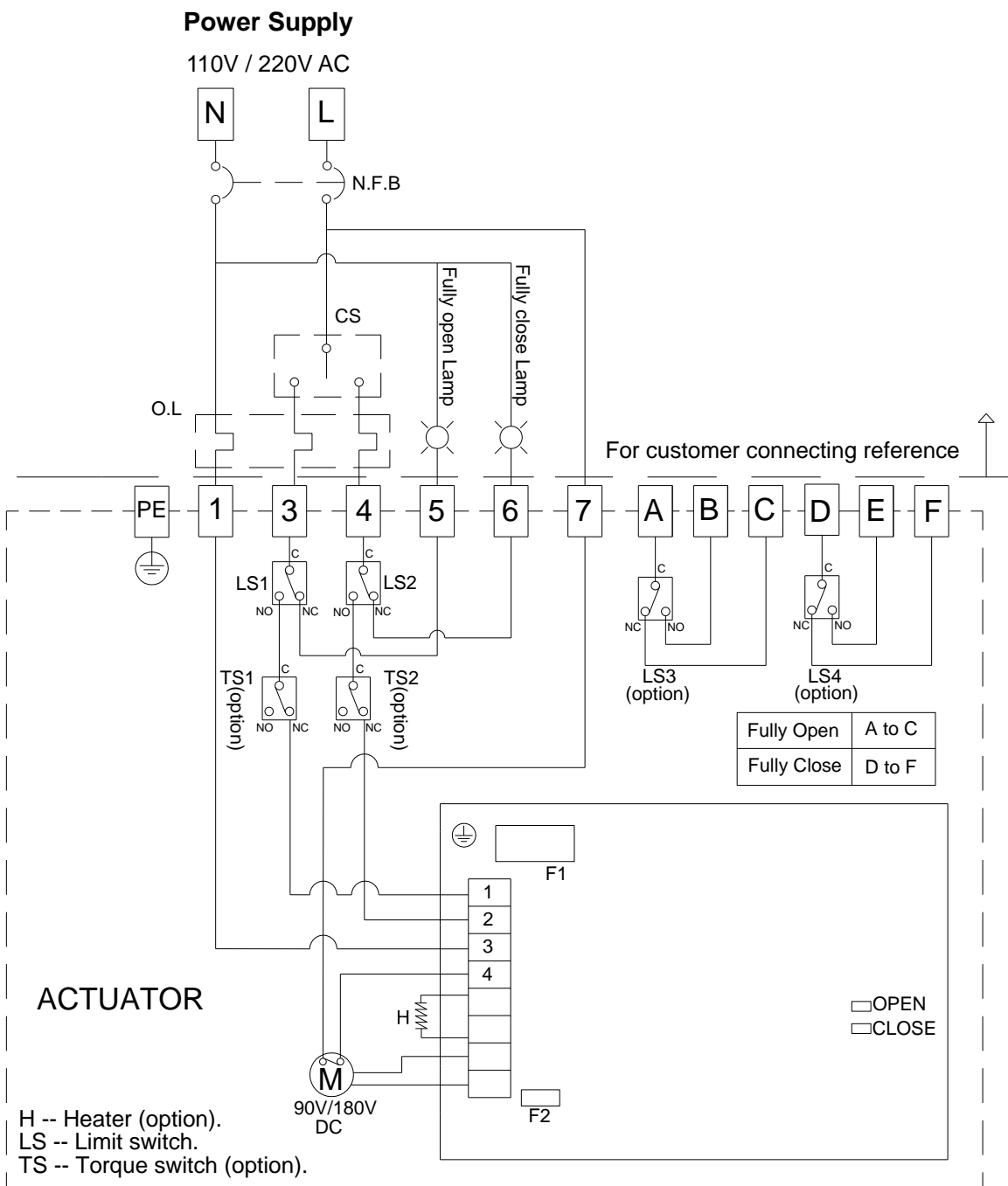

NOTE :

1. "N" connects to #1, "L" connects to #7.
2. "L" connects to #3 for "OPEN", "L" connects to #4 for "CLOSE".
3. Using less than 5A current for "A, B, C, D, E, F".

WIRING DIAGRAM – Quarter Turn Actuator

OM-9 ~ OM-13 220V AC 1-Phase

On-Off Controller , 50% duty cycle

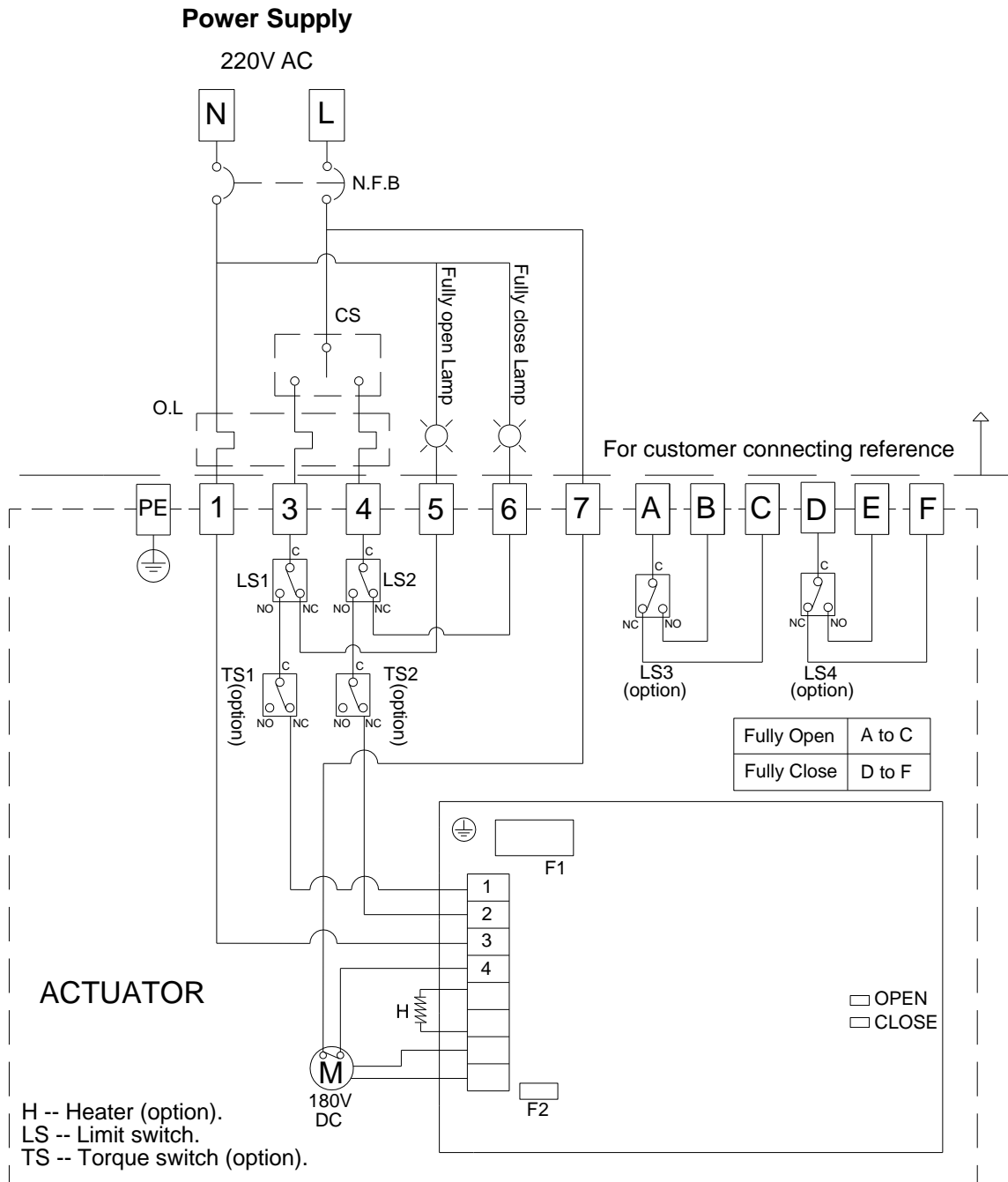

NOTE :

1. "N" connects to #1, "L" connects to #7.
2. "L" connects to #3 for "OPEN", "L" connects to #4 for "CLOSE".
3. Using less than 5A current for "A, B, C, D, E, F".

WIRING DIAGRAM – Quarter Turn Actuator

OM-2 ~ OM-13 110V , 220V AC 1-Phase

On-Off Controller , Analog Signal Output

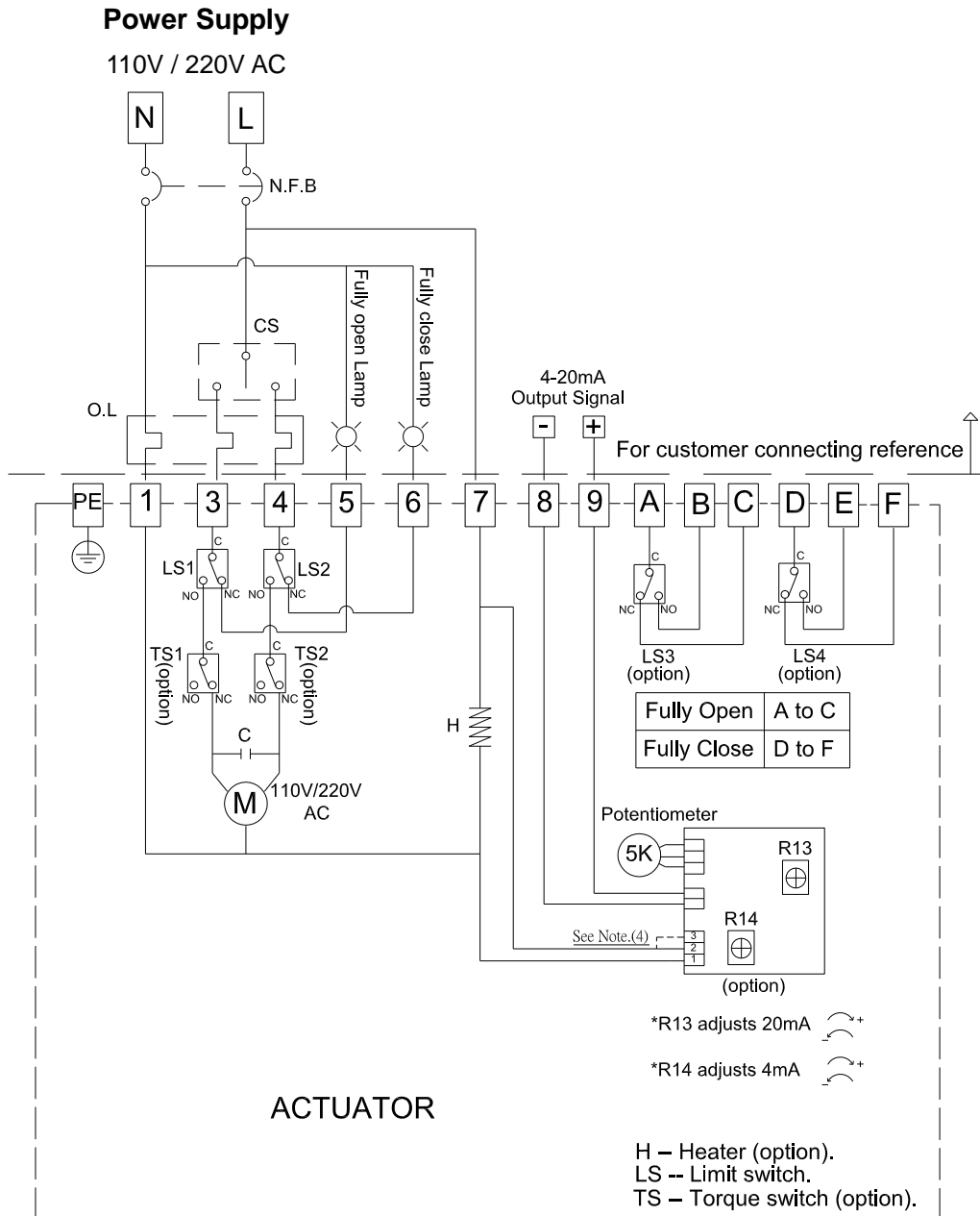

NOTE:

1. "N" connects to #1, " L " connects to #7.
2. "L" connects to #3 for "OPEN", "L" connects to #4 for "CLOSE".
3. Using less than 5A current for "A, B, C, D, E, F".
4. If the control power is 220V AC, N & L connect to #1 & #3.
If the control power is 110V AC, N & L connect to #1 & #2 or #2 & #3.

WIRING DIAGRAM – Quarter Turn Actuator

OM-2 ~ OM-13 220V , 380V , 440V AC 3-Phase

On-Off Controller , Analog Signal Output

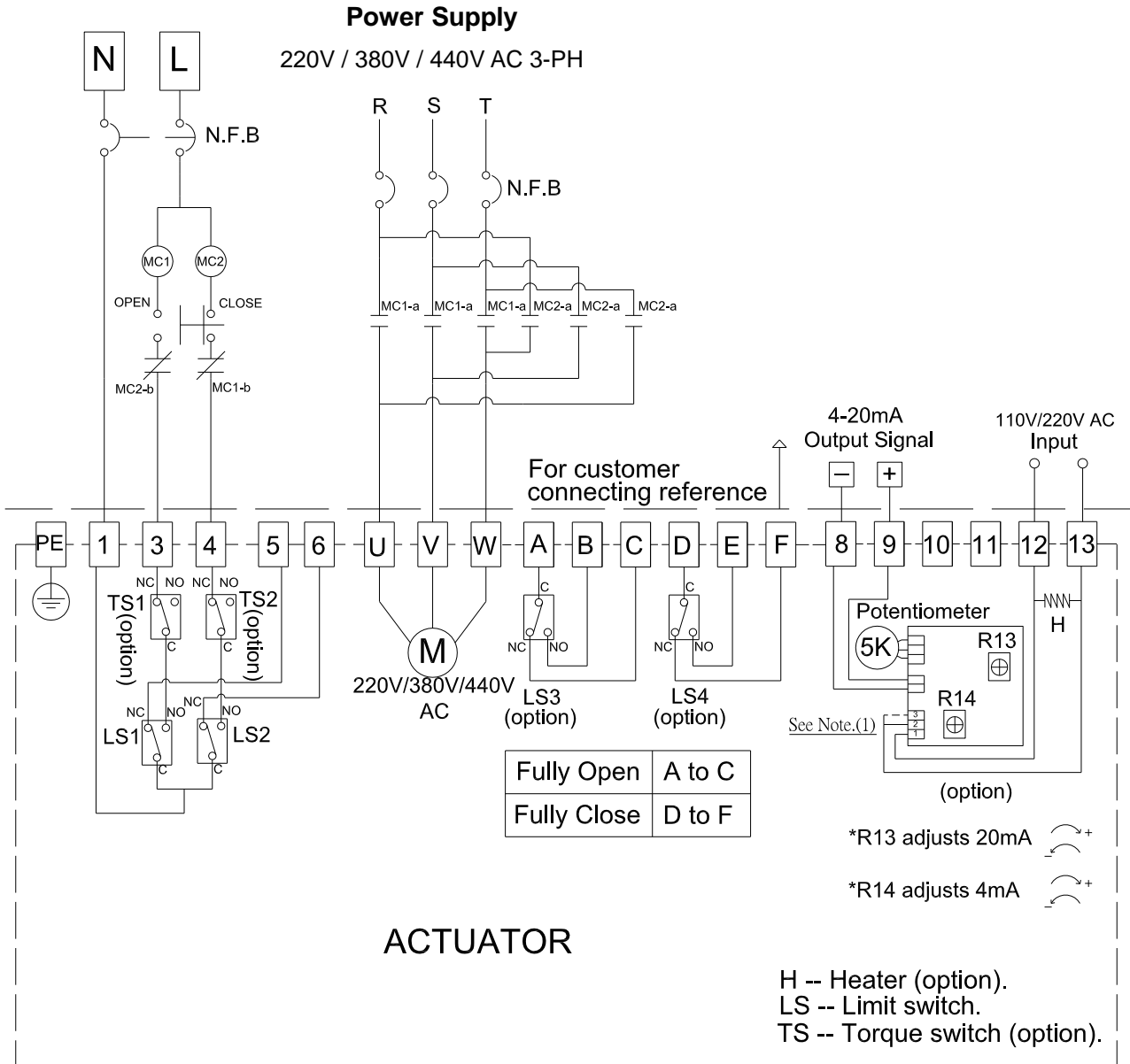

NOTE:

1. If the control power is 220V AC, N & L connect to #1 & #3.
If the control power is 110V AC, N & L connect to #1 & #2 or #2 & #3.
2. Using the hand-wheel to turn the actuator to 45 degree before test. If the operating direction is opposite after supplying power, please change any two of the U, V, W.
3. Using less than 5A current for "A, B, C, D, E, F".

WIRING DIAGRAM – Quarter Turn Actuator

OM-2 ~ OM-6 12V DC

OM-2 ~ OM-12 , OM-F , OM-G 24V DC

Modulating Controller

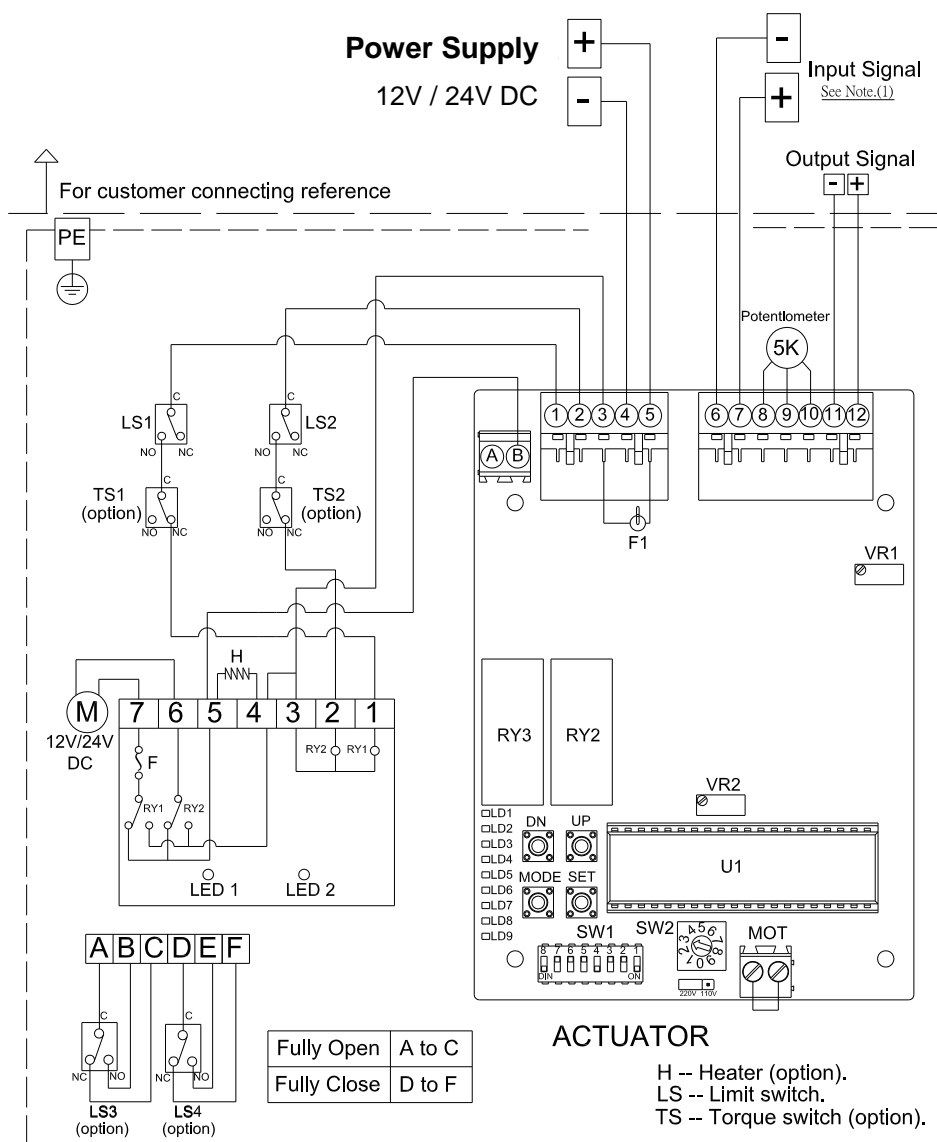

NOTE:

1. Modulating Board

- a. Input Signal : 4~20mA, 1~5V, 2~10V
 (It is suggested to use the shielding wire and its length should not exceed 30m.)
- b. Output Signal : 4~20mA, 2~10V

- 2. Using less than 5A current for "A, B, C, D, E, F".
- 3. Using battery to supply power for DC units.

WIRING DIAGRAM – Quarter Turn Actuator

OM-2 ~ OM-12 , OM-F , OM-G 24V AC

Modulating Controller

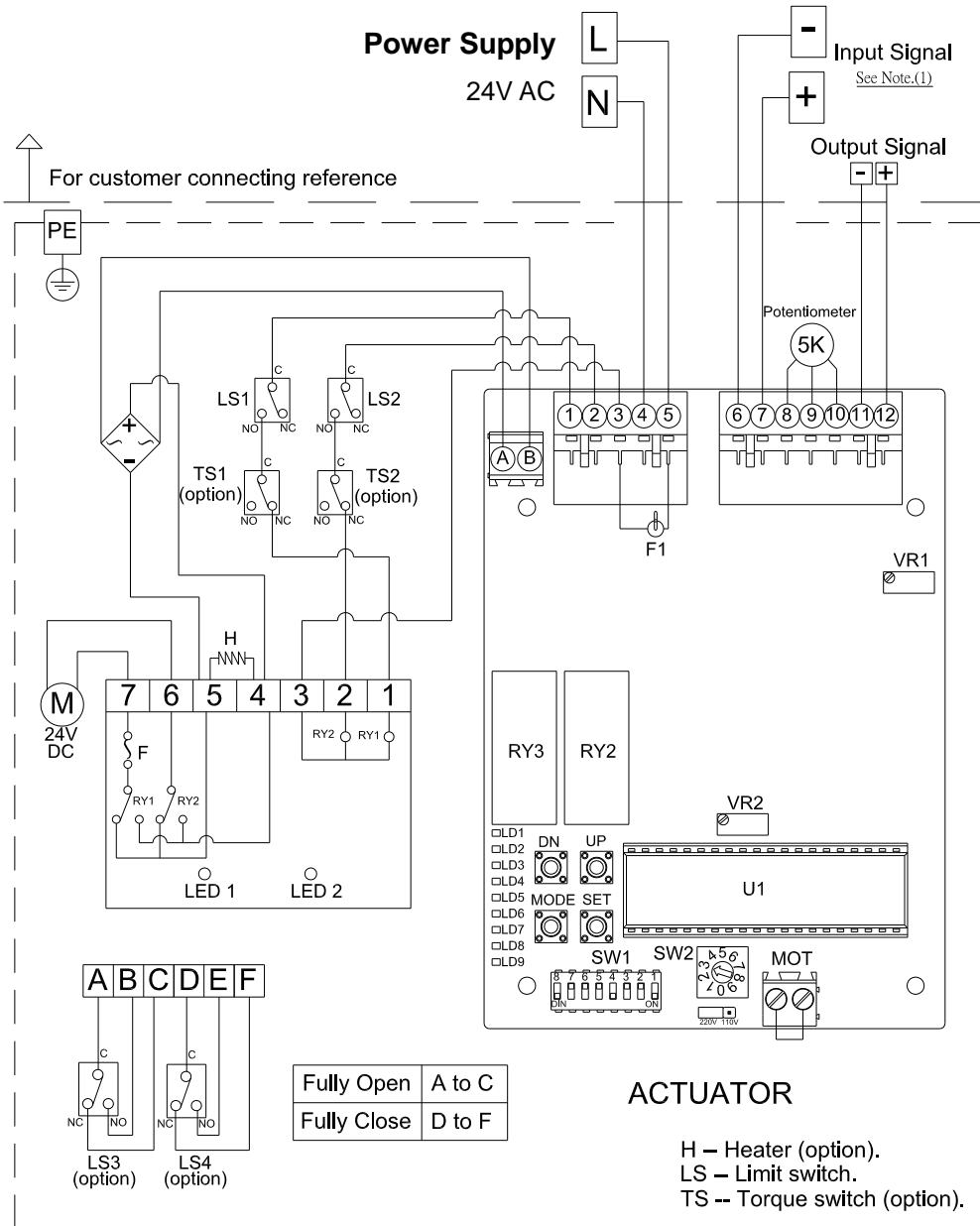

NOTE:

1. **Modulating Board**
 - a. Input Signal : 4~20mA, 1~5V, 2~10V
 (It is suggested to use the shielding wire and its length should not exceed 30m.)
 - b. Output Signal : 4~20mA, 2~10V
2. Using less than 5A current for “A, B, C, D, E, F”.

WIRING DIAGRAM – Quarter Turn Actuator

OM-2 ~ OM-8 , OM-F , OM-G 110V , 220V AC 1-Phase

Modulating Controller

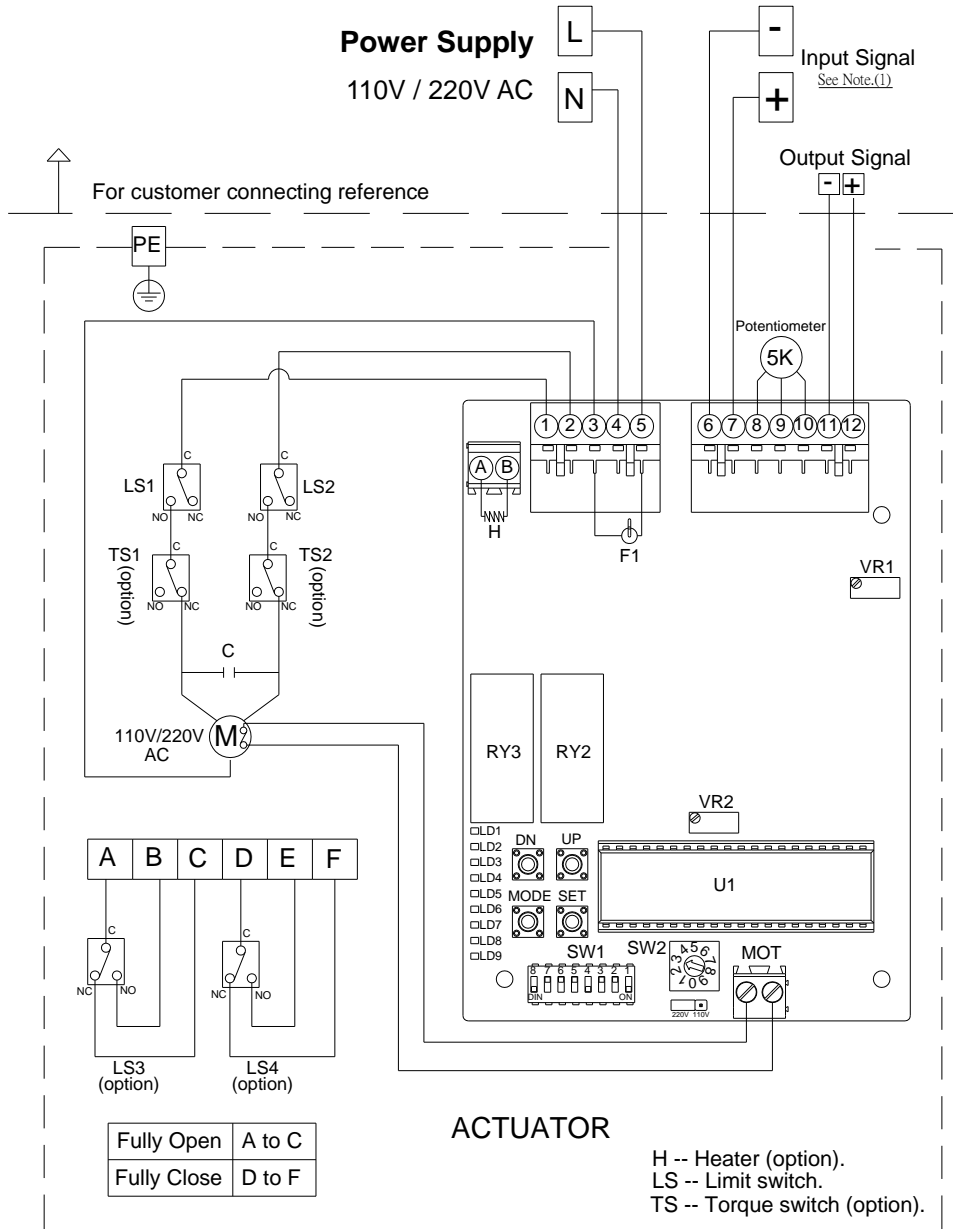

NOTE:

1. **Modulating Board**

- a. Input Signal : 4~20mA, 1~5V, 2~10V
(It is suggested to use the shielding wire and its length should not exceed 30m.)
- b. Output Signal : 4~20mA, 2~10V

- 2. Using less than 5A current for "A, B, C, D, E, F".

WIRING DIAGRAM – Quarter Turn Actuator

OM-2 ~ OM-13 220V , 380V , 440V AC 3-Phase

Modulating Controller

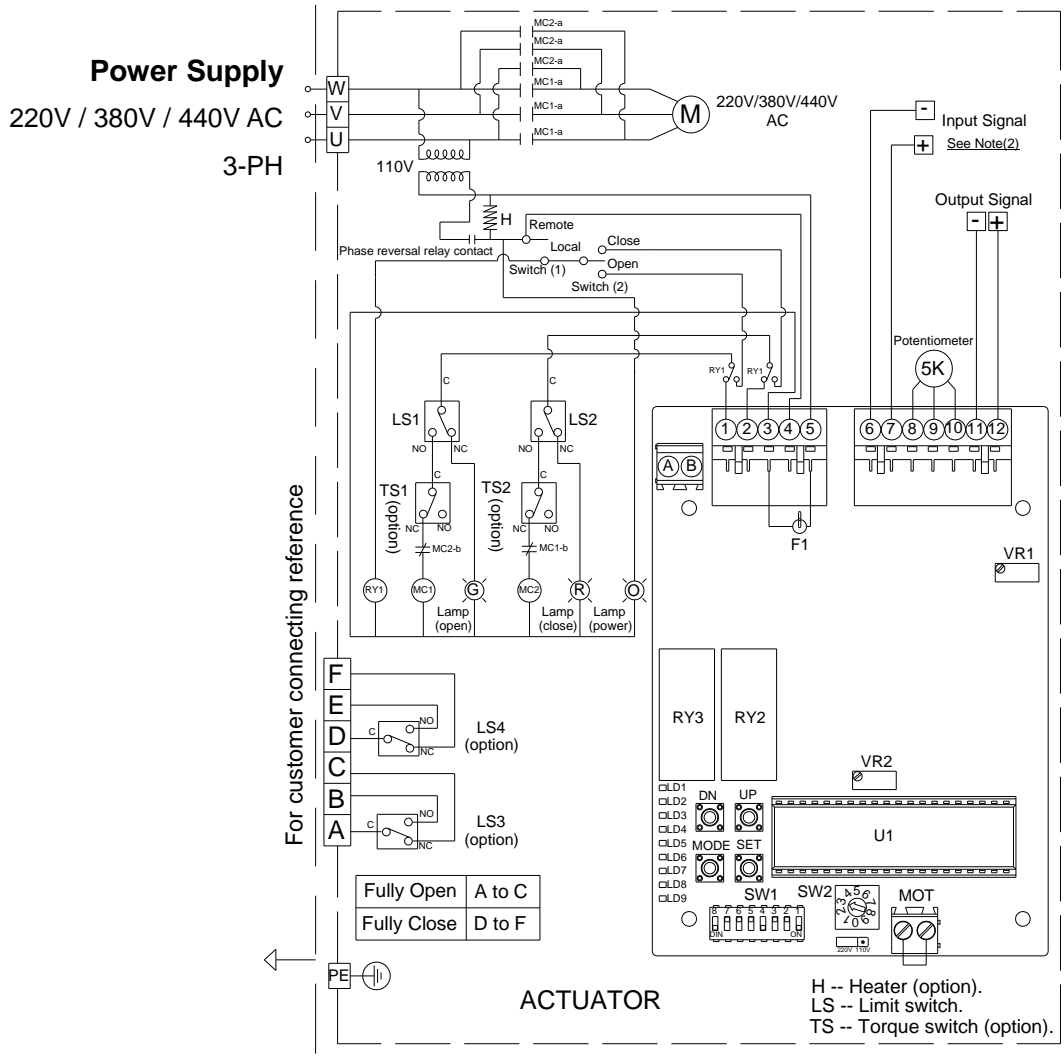

- NOTE:**
1. Please change any two of the U, V, W when the power lamp is off.
 2. **Modulating Board**
 - a. Input Signal : 4~20mA, 2~10V, 1~5V
(It is suggested to use the shielding wire and its length should not exceed 30m.)
 - b. Output Signal: 4~20mA, 2~10V
 3. **Local / Remote Switches**
 - a. Select "Remote" : Controlled by signal.
 - b. Select "Local" : Controlled by switch (2).
 4. Using less than 5A current for "A, B, C, D, E, F".

WIRING DIAGRAM – Quarter Turn Actuator

OM-2 ~ OM-8 110V , 220V AC 1-Phase

Modulating Controller , 75% duty cycle

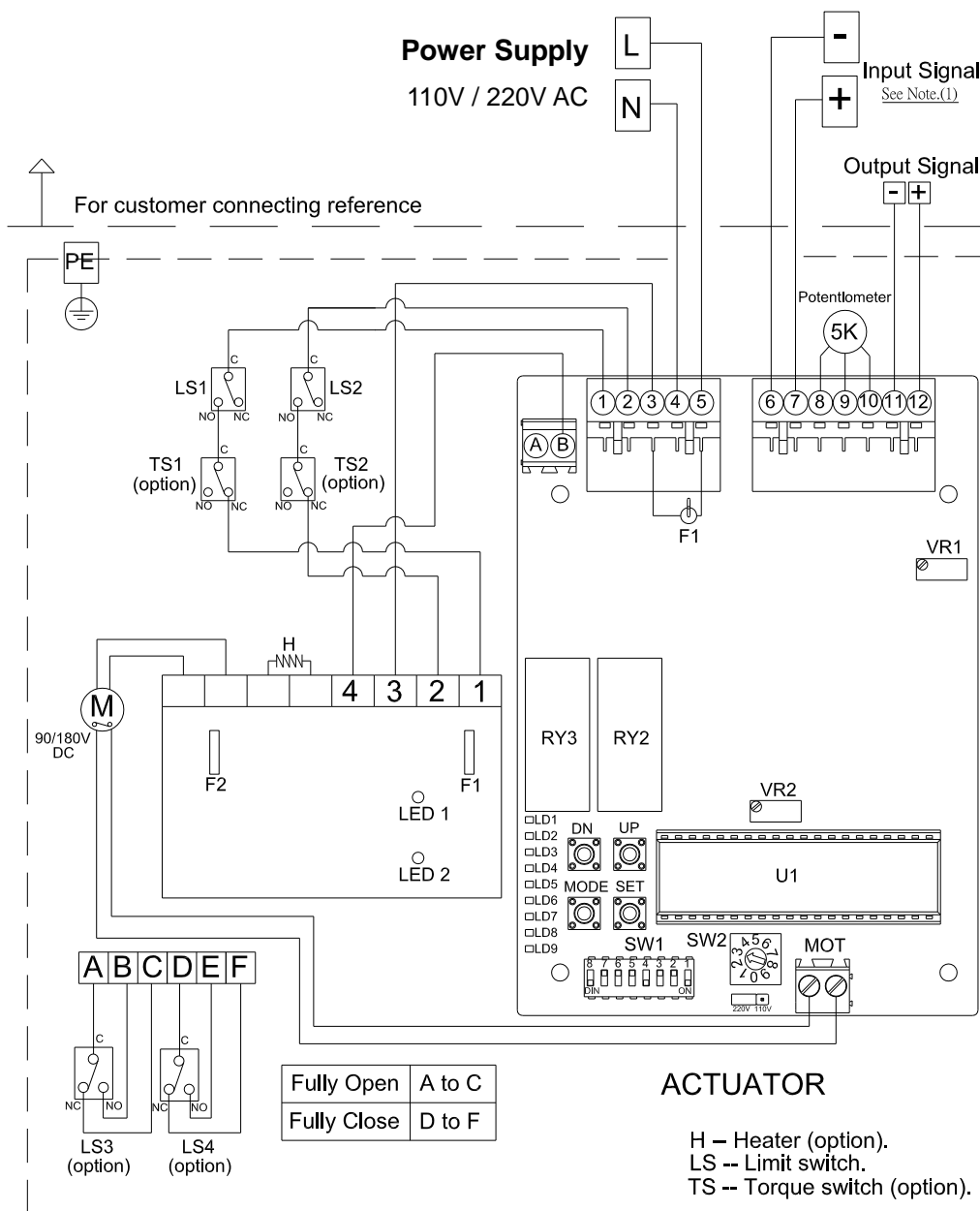

NOTE:

1. **Modulating Board**
 - a. Input Signal : 4~20mA, 1~5V, 2~10V
 (It is suggested to use the shielding wire and its length should not exceed 30m.)
 - b. Output Signal : 4~20mA, 2~10V
2. Using less than 5A current for “A, B, C, D, E, F”.

WIRING DIAGRAM – Quarter Turn Actuator

OM-9 ~ OM-13 110V AC 1-Phase

Modulating Controller , 50% duty cycle

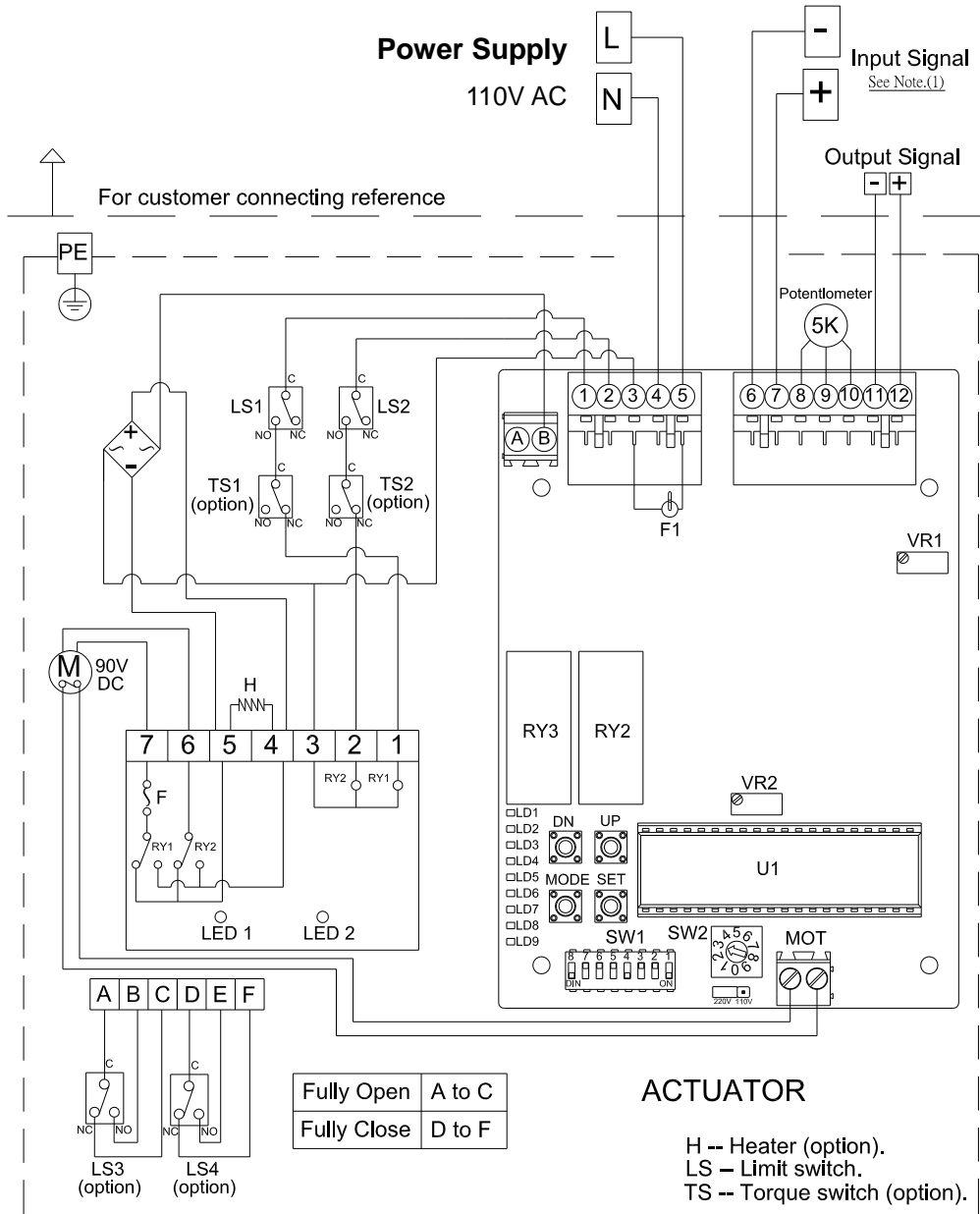

NOTE:

1. **Modulating Board**
 - a. Input Signal : 4~20mA, 1~5V, 2~10V
 (It is suggested to use the shielding wire and its length should not exceed 30m.)
 - b. Output Signal : 4~20mA, 2~10V
2. Using less than 5A current for "A, B, C, D, E, F".

WIRING DIAGRAM – Quarter Turn Actuator

OM-9 ~ OM-13 220V AC 1-Phase

Modulating Controller , 50% duty cycle

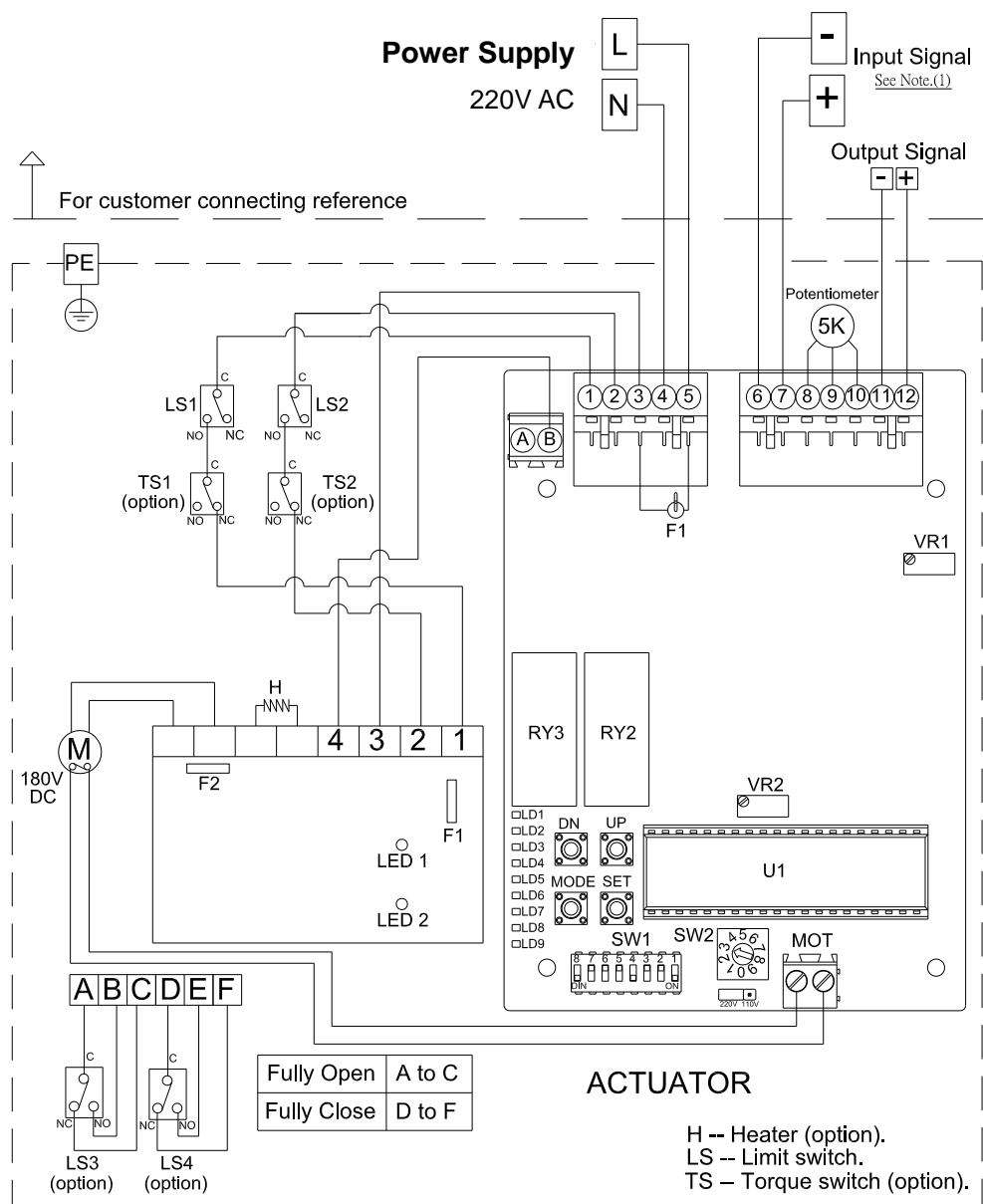

NOTE:

1. Modulating Board

- a. Input Signal : 4~20mA, 1~5V, 2~10V
 (It is suggested to use the shielding wire and its length should not exceed 30m.)
- b. Output Signal : 4~20mA, 2~10V

2. Using less than 5A current for "A, B, C, D, E, F".

WIRING DIAGRAM – Quarter Turn Actuator

OM-2 ~ OM-13 110V , 220V AC 1-Phase

On-Off Controller , Local Control Unit

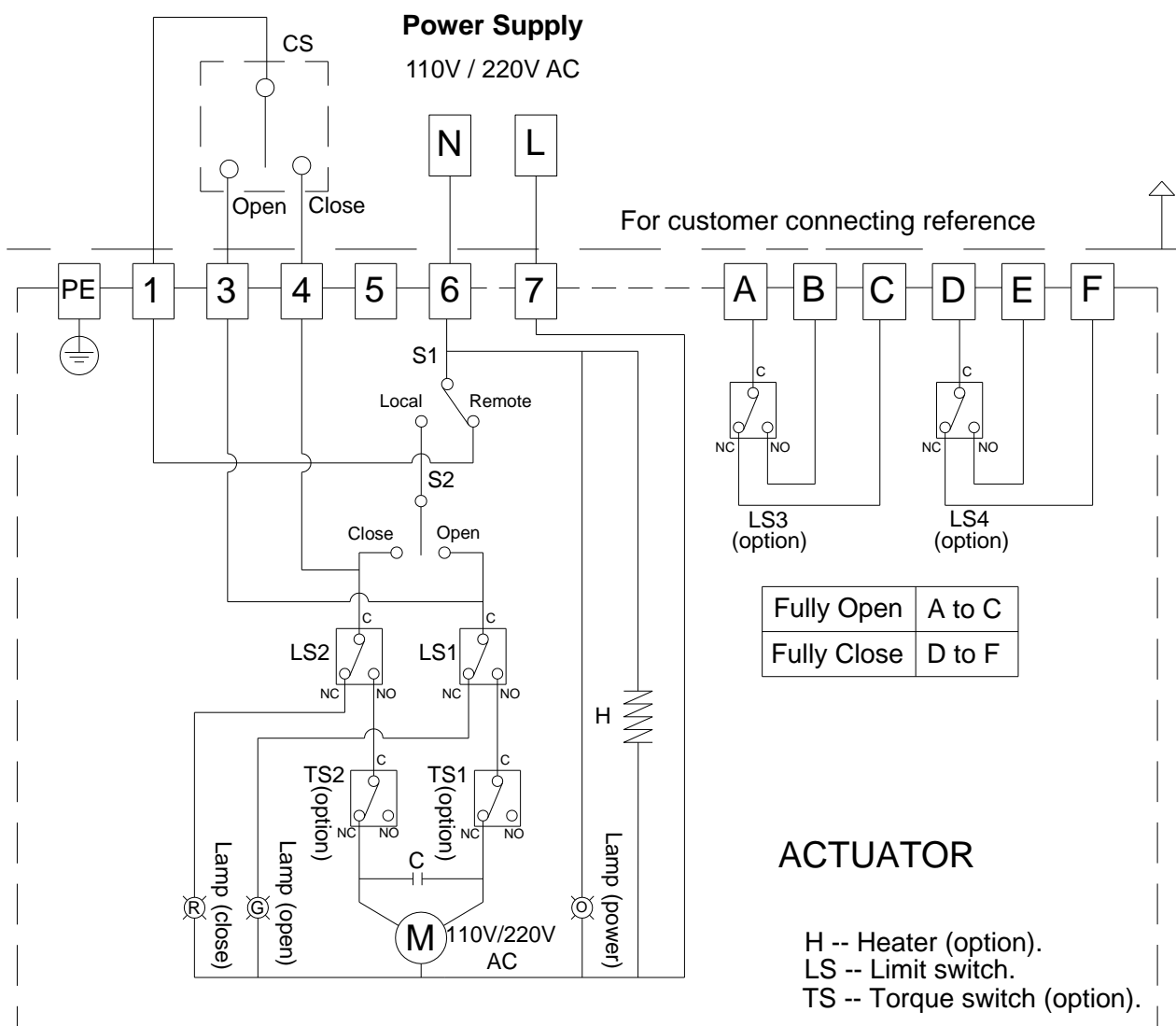

NOTE:

1. Using less than 5A current for "A, B, C, D, E, F".

WIRING DIAGRAM – Quarter Turn Actuator

OM-2 ~ OM-13 220V , 380V , 440V AC 3-Phase

On-off Controller , Local Control Unit

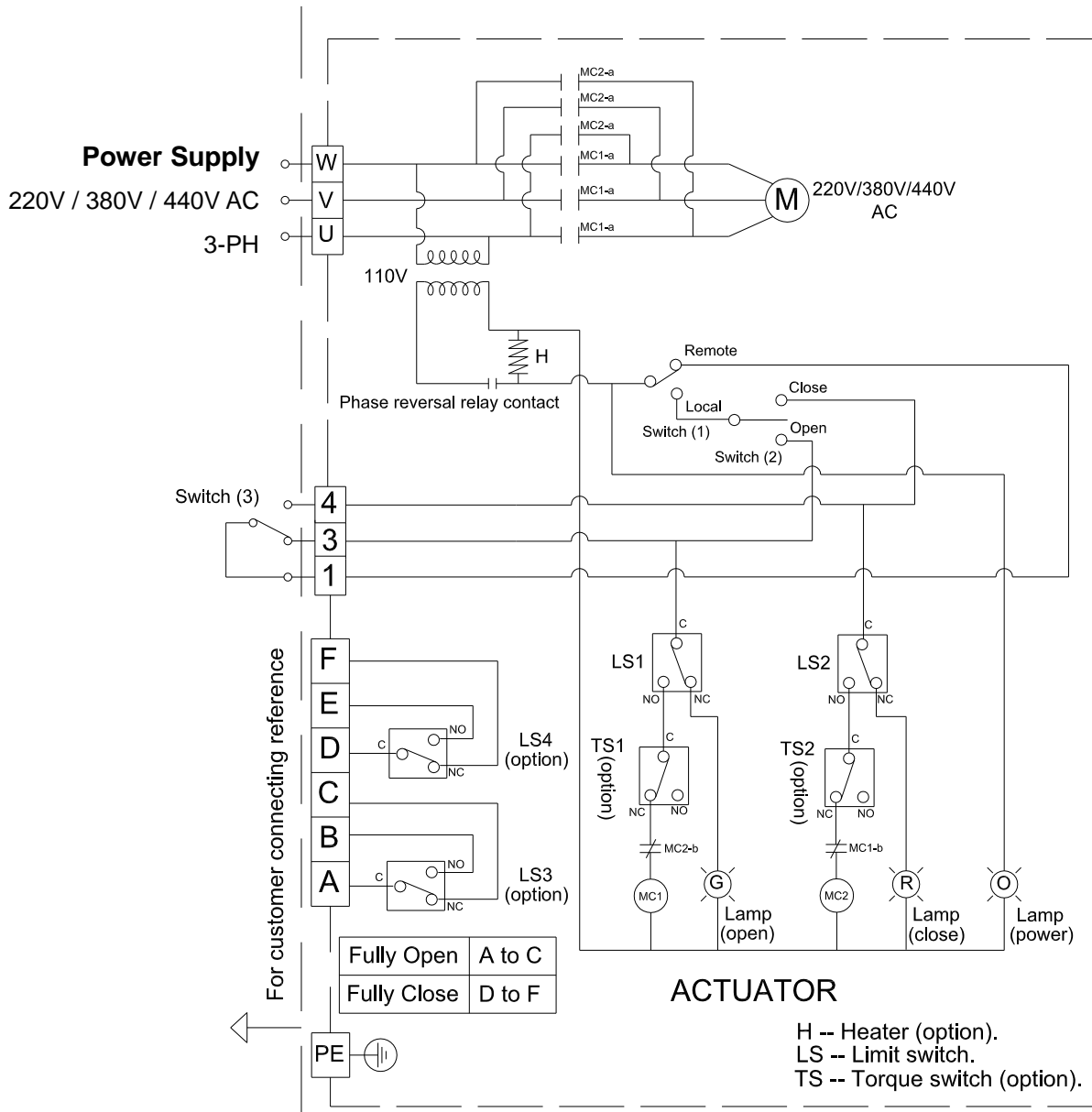

NOTE :

1. Please change any two of the U, V, W when the power lamp is off.
2. Switch (3) is the switch of remote control (provided by user).
 - a. Connecting #1 & #3 for OPEN.
 - b. Connecting #1 & #4 for CLOSE.
 - c. #1, #3, #4 can not connect together at the same time.
3. Using less than 5A current for "A,B, C, D, E, F".

WIRING DIAGRAM – Quarter Turn Actuator

OM-2 ~ OM-8 110V , 220V AC 1-Phase

Modulating Controller , Local Control Unit

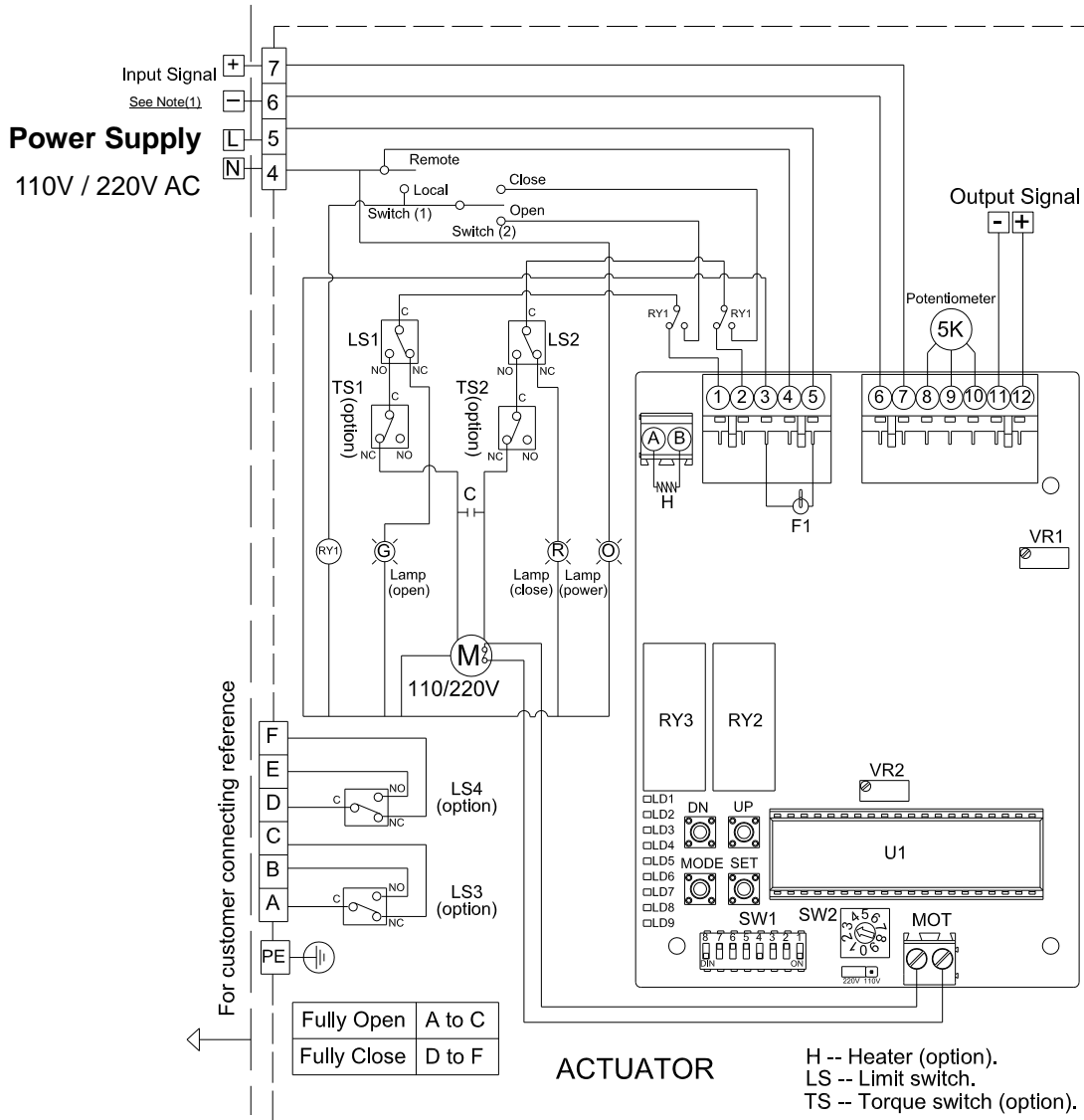

NOTE :

1. **Modulating Board**
 - a. Input Signal : 4~20mA, 1~5V, 2~10V
(It is suggested to use the shielding wire and its length should not exceed 30m.)
 - b. Output Signal : 4~20mA, 2~10V
2. **Local / Remote Switches**
 - a. Select "Remote" : Controlled by signal.
 - b. Select "Local" : Controlled by switch (2).
3. Using less than 5A current for "A, B, C, D, E, F".

WIRING DIAGRAM – Quarter Turn Actuator

OM-2 ~ OM-8 110V , 220V AC 1-Phase

Modulating Controller , Local Control Unit , 75% duty cycle

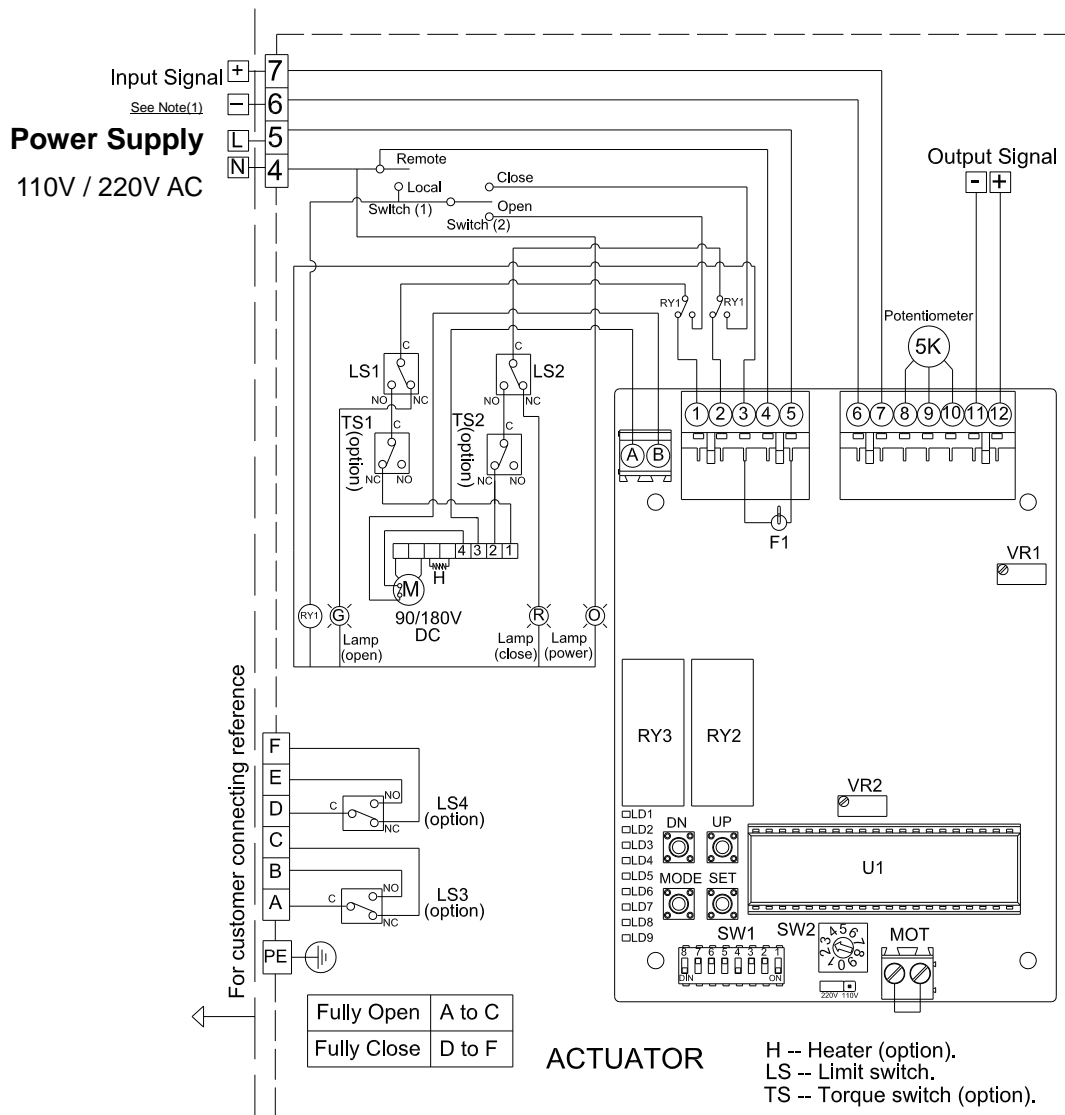

NOTE :

1. **Modulating Board**
 - a. Input Signal : 4~20mA, 1~5V, 2~10V
(It is suggested to use the shielding wire and its length should not exceed 30m.)
 - b. Output Signal : 4~20mA, 2~10V
2. **Local / Remote Switches**
 - a. Select "Remote" : Controlled by signal.
 - b. Select "Local " : Controlled by switch (2).
3. Using less than 5A current for "A, B, C, D, E, F".

WIRING DIAGRAM – Quarter Turn Actuator

OM-9 ~ OM-13 110V AC 1-Phase

Modulating Controller , Local Control Unit , 50% duty cycle

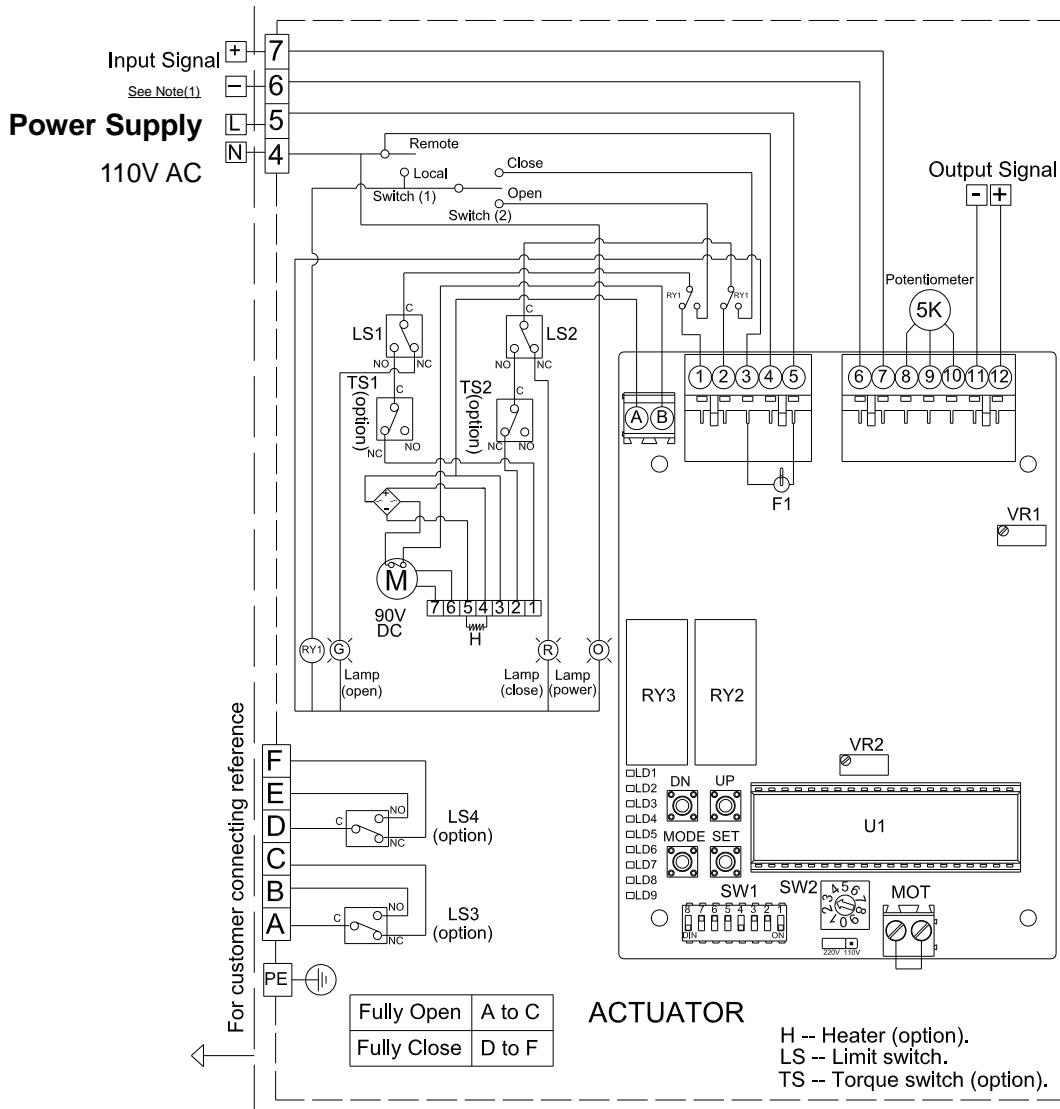

NOTE :

1. **Modulating Board**
 - a. Input Signal : 4~20mA, 1~5V, 2~10V
 (It is suggested to use the shielding wire and its length should not exceed 30m.)
 - b. Output Signal : 4~20mA, 2~10V
2. **Local/Remote Switches**
 - a. Select "Remote" : Controlled by signal.
 - b. Select "Local" : Controlled by switch (2).
3. Using less than 5A current for "A, B, C, D, E, F".

WIRING DIAGRAM – Quarter Turn Actuator

OM-9 ~ OM-13 220V AC 1-Phase

Modulating Controller , Local Control Unit , 50% duty cycle

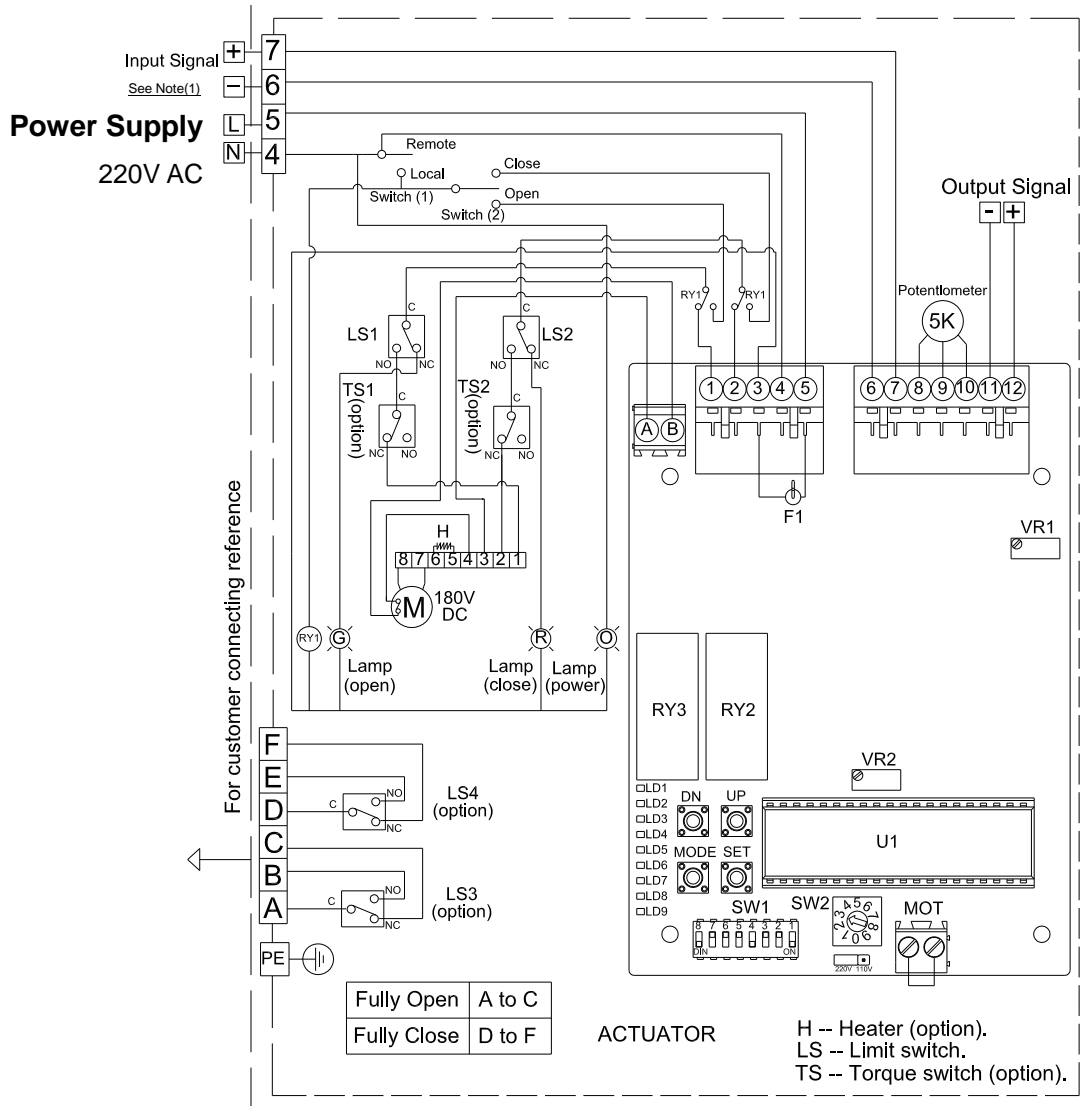

NOTE :

1. **Modulating Board**
 - a. Input Signal : 4~20mA, 1~5V, 2~10V
(It is suggested to use the shielding wire and its length should not exceed 30m.)
 - b. Output Signal : 4~20mA, 2~10V
2. **Local / Remote Switches**
 - a. Select "Remote" : Controlled by signal.
 - b. Select "Local" : Controlled by switch (2).
3. Using less than 5A current for "A, B, C, D, E, F".

WIRING DIAGRAM – Quarter Turn Actuator

OM-2 ~ OM-13 110V , 220V AC 1-Phase

On-off Controller , Local Control Unit , Analog Signal Output

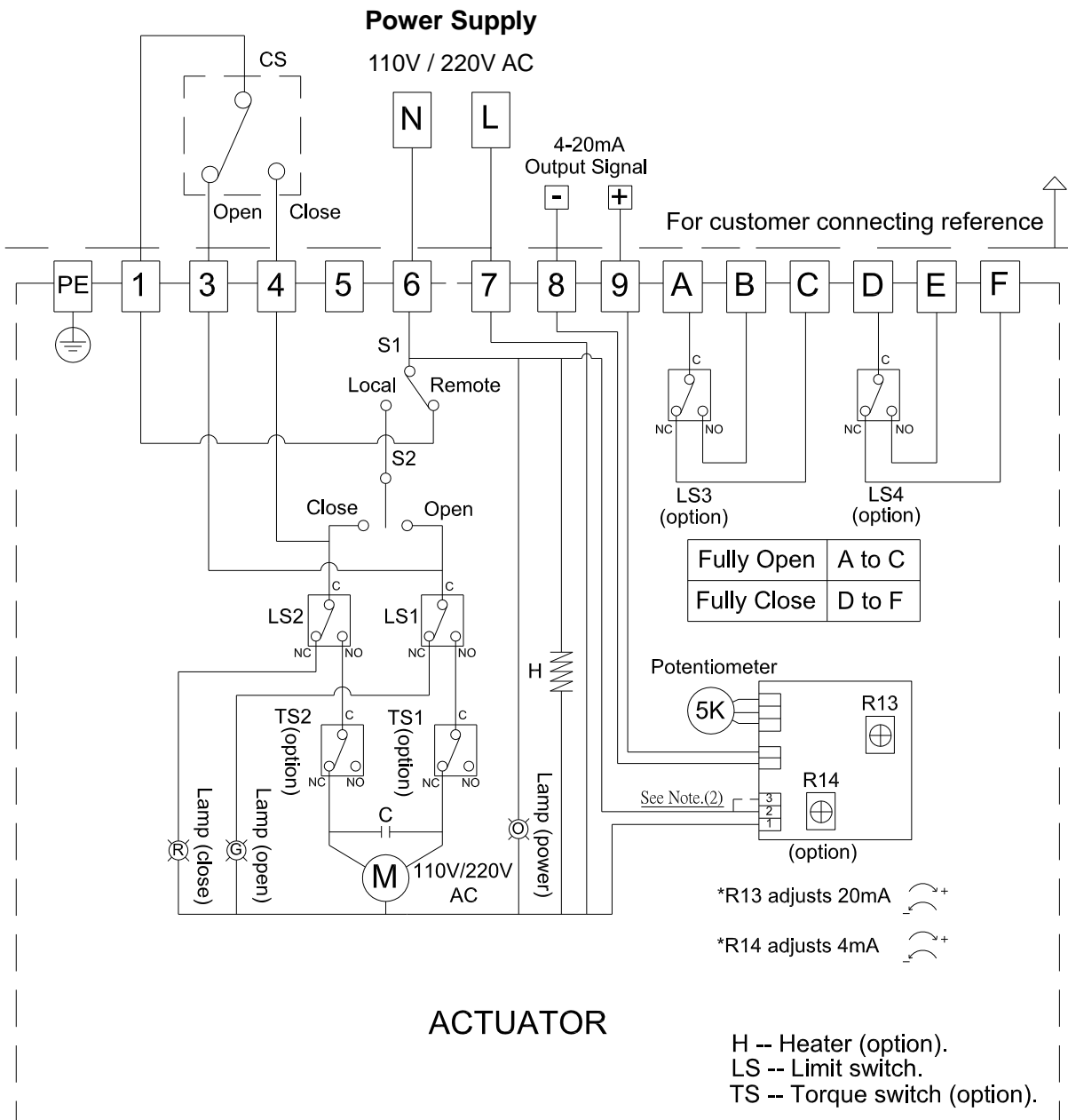

NOTE :

- Using less than 5A current for "A, B, C, D, E, F".
- If the control power is 220V AC, N & L connect to #1 & #3.
If the control power is 110V AC, N & L connect to #1 & #2 or #2 & #3.

WIRING DIAGRAM – Quarter Turn Actuator

OM-2 ~ OM-13 220V , 380V , 440V AC 3-Phase

On-off Controller , Local Control Unit , Analog Signal Output

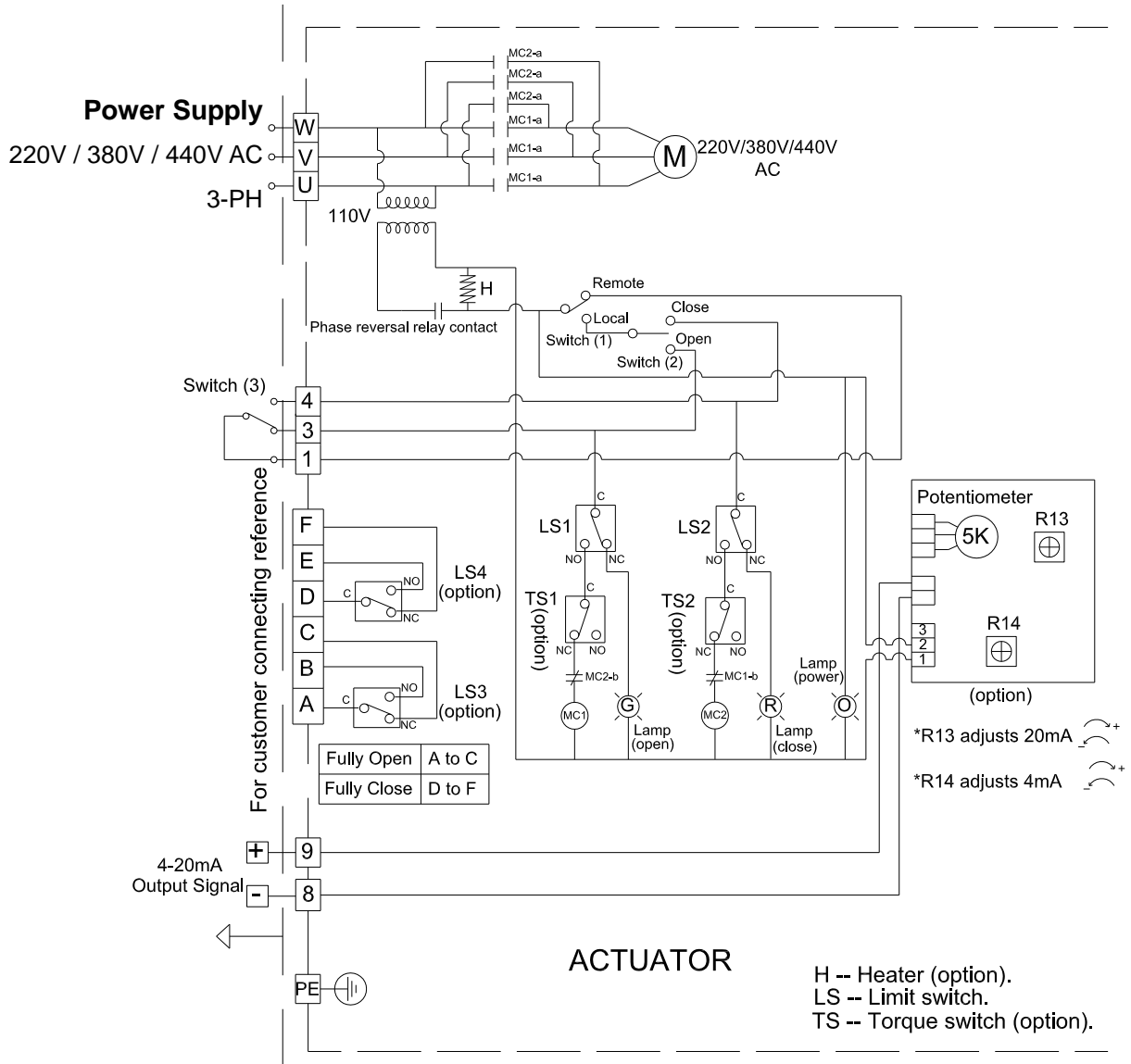

- NOTE :**
- Please change any two of the U, V, W when the power lamp is off.
 - Switch (3) is the switch of remote control (provided by user).
 - Connecting #1 & #3 for OPEN.
 - Connecting #1 & #4 for CLOSE.
 - #1, #3, #4 can not connect together at the same time.
 - Using less than 5A current for "A,B, C, D, E, F".

WIRING DIAGRAM – Quarter Turn Actuator

BM-2, OM-A, OM-A-M, OM-1~OM-13, OM-F, OM-G 110V, 220V AC 1-Phase

Same Switch Coupling Wiring

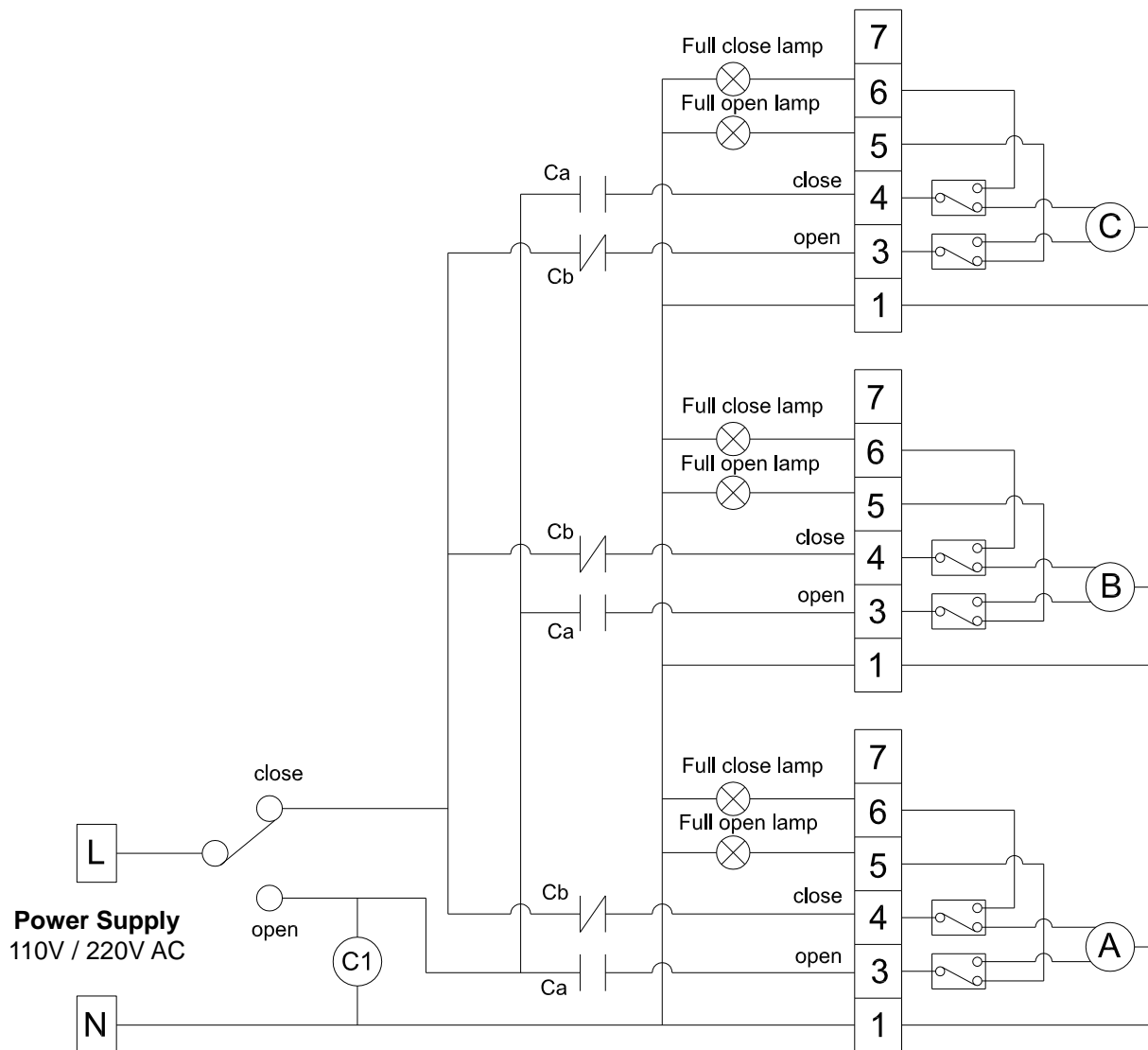

NOTE :

1. The wiring is based on 3 sets of actuators for one switch – 1 set is open and 2 sets are close. (If more sets, the rest can be done by this logic.)
2. When a set of control wire or switch needs to control two or more actuators at the same time, please refer to the wiring diagram.
3. Add one contactor for separation to prevent the interference of compression coupling.
4. C1=3a3b contactor

ADJUSTMENT – Travel Cam & Limit Switches

NOTE:

If LS3 & LS4 are fitted, they should be set to trip prior to LS1 & LS2 to avoid over-travel.

The travel cams are set to control the open and closed position of the valve. The position is set to stop the travel of the actuator when the travel cams activate the limit switch. Standard is two limit switches (LS1 & LS2), one for open, one for closed. LS1 & LS2 limit the maximum range by disabling the electric motor. LS3 & LS4 are optional. They allow external equipment to confirm that the valve has reached the fully open and fully closed positions.

The travel cams can be adjusted with a 2.5mm Allen key. The cams are preset at the factory. When additional adjustments are needed, follow steps described below.

OM-A, OM-A-M

1. To set the open position:

- a. Turn power off.
- b. Use manual override to turn valve to the fully-open position.
- c. Remove cover and loosen the M5 set screw on the TC1 with a 2.5mm Allen Key.
- d. Rotate cam(TC1) counterclockwise to contact with switch.
- e. Slowly rotate cam(TC1) clockwise until a light click is heard.
- f. Securely tighten the M5 set screw and apply power to check the travel position. If the position is not correct, please repeat steps a ~ f.
- g. After the adjustment is completed, check again the M5 set screw is securely tightened.

2. To set the close position:

- a. Turn power off.
- b. Use manual override to turn valve to the fully-closed position.
- c. Loosen the M5 set screw on the TC2 with a 2.5mm Allen key.
- d. Rotate cam(TC2) clockwise to contact with switch.
- e. Slowly rotate cam(TC2) counterclockwise until a light click is heard.
- f. Securely tighten the set screw and apply power to check the traveling position. If the position is not correct, please repeat steps a ~ f.
- g. After the adjustment is completed, check again the M5 set screw is securely tightened.

Modulating type: Loosen M5 set screw on round gear before setting, after completing fully-open and fully-closed calibration, run the actuator to fully-closed position, then rotate round gear counterclockwise to the end and tighten M5 set screw.

ADJUSTMENT – Travel Cam & Limit Switches

【OM-A, OM-A-M】

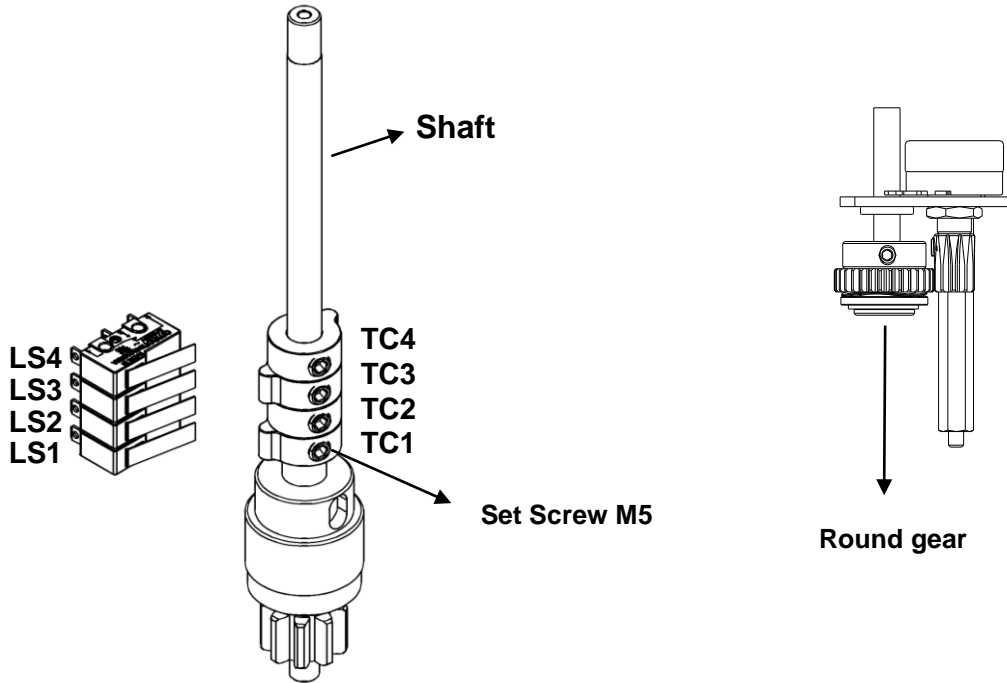

- TC 4 Synchronous turn with TC2 (optional).**
- TC 3 Synchronous turn with TC1 (optional).**
- TC 2 “CLOSE”**
 - Clockwise: increase closing degree to fully closed.**
 - Counterclockwise: decrease closing degree.**
- TC 1 “ OPEN”**
 - Clockwise: decrease opening degree.**
 - Counterclockwise: increase opening degree to fully open.**

OM-1, BM-2, OM2~13, OM-F, OM-G

1. To set the open position:

- a. Turn power off and loosen both mechanical stops (Please refer to P52 and except OM-A, BM-2, OM-A, OM-A-M).
- b. Use manual override to turn valve to the fully-open position.
- c. Remove cover and loosen the M5 set screw on the TC1 with a 2.5mm Allen key.
- d. Rotate cam(TC1) clockwise to contact with switch.
- e. Slowly rotate cam(TC1) counterclockwise until a light click is heard.
- f. Securely tighten the set screw and apply power to check the travel position. If the position is not correct, please repeat steps a ~ f.
- g. After the adjustment is completed, check again the M5 set screw is securely tightened.

ADJUSTMENT – Travel Cam & Limit Switches

2. To set the close position:

- a. Turn power off.
- b. Use manual override to turn valve to the fully closed position.
- c. Loosen the M5 set screw on the TC2 with a 2.5mm Allen key.
- d. Rotate cam(TC2) counterclockwise to contact with switch.
- e. Slowly rotate cam(TC2) clockwise until a light click is heard.
- f. Securely tighten the set screw and apply power to check the travel position. If the position is not correct, please repeat steps a ~ f.
- g. After the adjustment is completed, check again the M5 set screw is securely tightened.
- h. Tighten both mechanical stops and per P52.

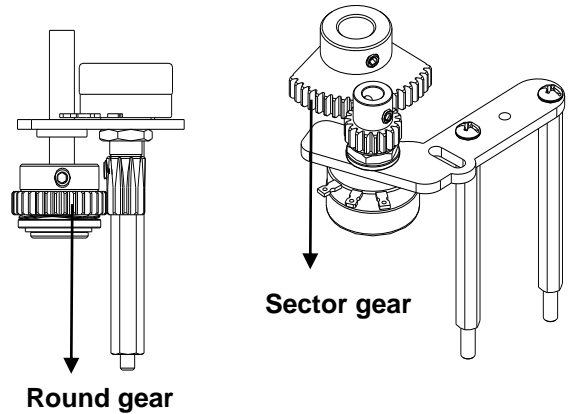

Modulating type: Loosen M5 set screw on sector gear (Round gear) before setting, after completing fully-open and fully-closed calibration, run the actuator to fully-closed position, then rotate sector gear (Round gear) clockwise to the end and tighten M5 set screw.

【OM-1】

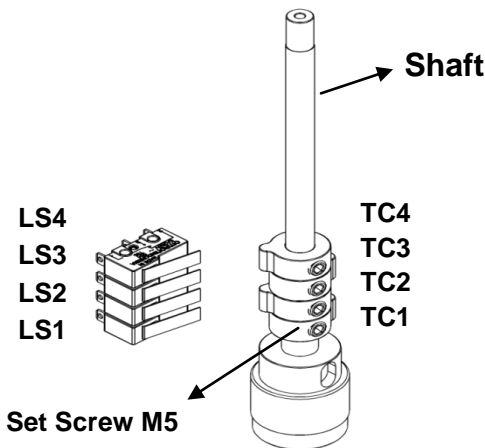

【BM-2, OM-2~13, OM-F, OM-G】

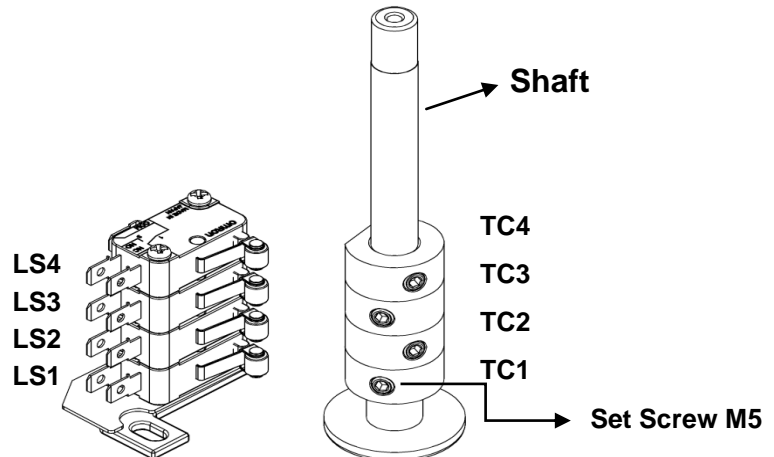

- TC 4 Synchronous turn with TC2 (optional).**
- TC 3 Synchronous turn with TC1 (optional).**
- TC 2 "CLOSE"**
 - ↻ **Clockwise: decrease closing degree.**
 - ↺ **Counterclockwise: increase closing degree to fully-closed.**
- TC 1 "OPEN"**
 - ↻ **Clockwise: increase opening degree to fully-open.**
 - ↺ **Counterclockwise: decrease opening degree.**

ADJUSTMENT – Mechanical Stops



CAUTION !

Mechanical stops should only be reached during manual operation.

The Mechanical stops are factory set, though in some cases adjustment may be required once a valve is fitted.

1. For Electric Operation

Please refer to “Adjustment – Travel Cam & Limit Switches”.

2. For Manual Operation

- a. Turn power off.
- b. Loosen locknut and unwind it a few turns.
- c. For modulating type, loosen the set screw on the sector gear first.
- d. Use manual override to turn the actuator to desire limit position.
- e. For modulating type, rotate sector gear clockwise to the end. Then tighten set screw.
- f. Tighten the mechanical stop screw until it reaches the shaft, then reverse one cycle.
- g. Tighten locknut.
- h. Check that the electrical limit switches can still be reached.

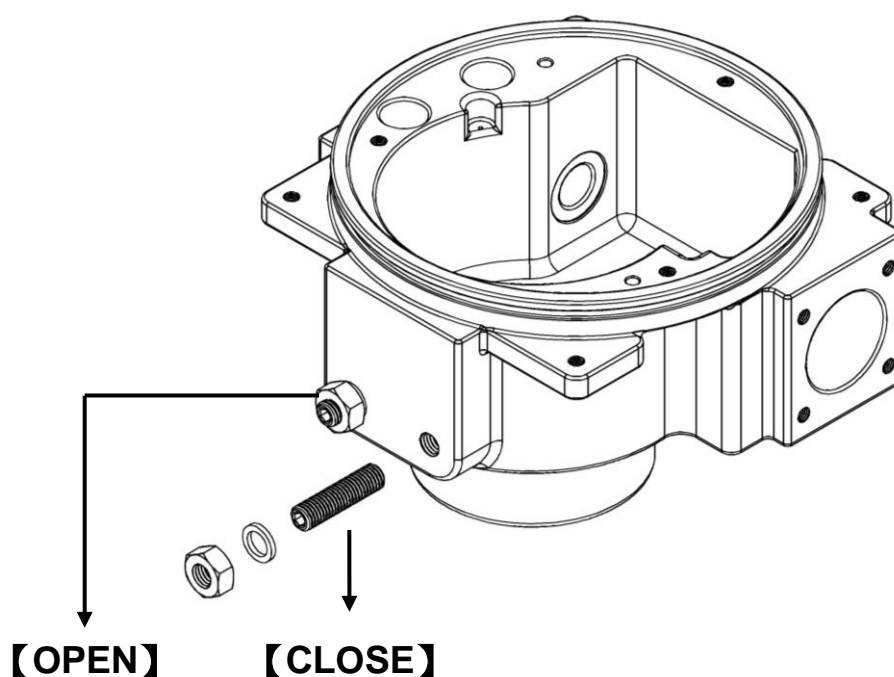

ADJUSTMENT – Modulating Control Board

Part A: Suitable for OM-1~OM-13、OM-A、OM-A-M、OM-F、OM-G

1. Surface The surface is based on the actuator in 110 / 220V voltage.
OM-1、OM-A、OM-A-M

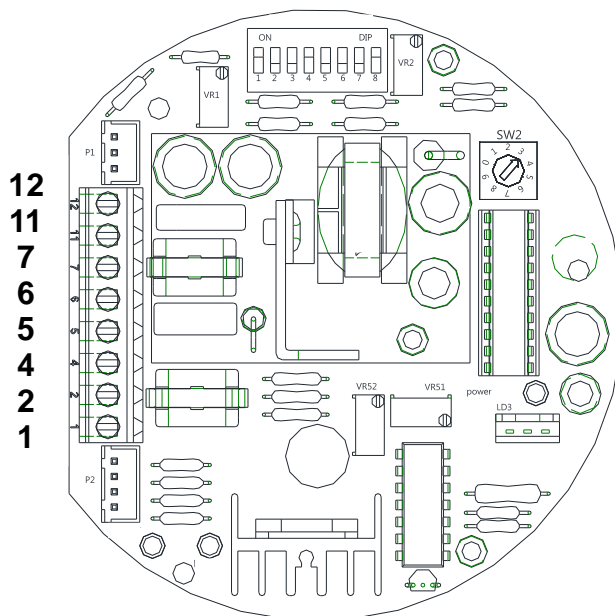

OM-2~OM-13、OM-F、OM-G

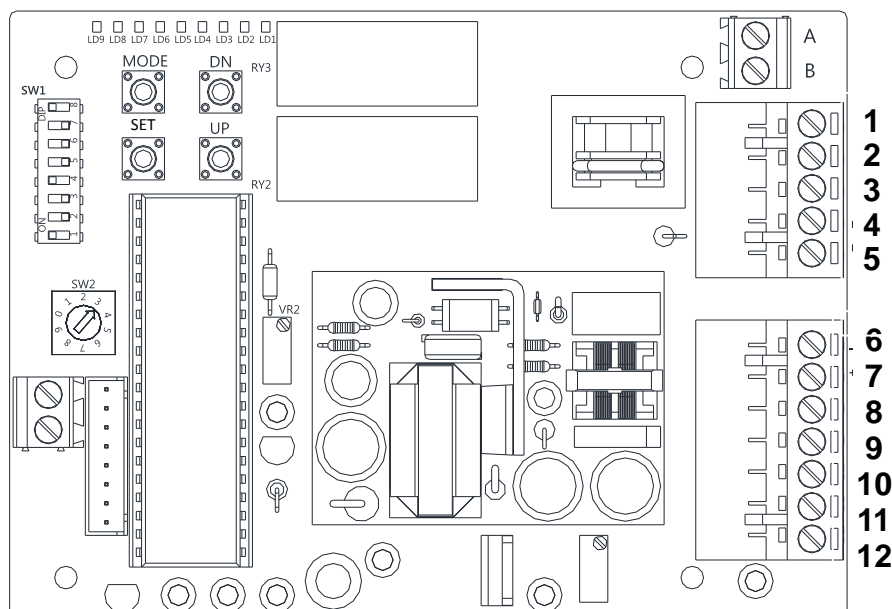

ADJUSTMENT – Modulating Control Board

Part A: Suitable for OM-1~OM-13、OM-A、OM-A-M、OM-F、OM-G

2. Procedure

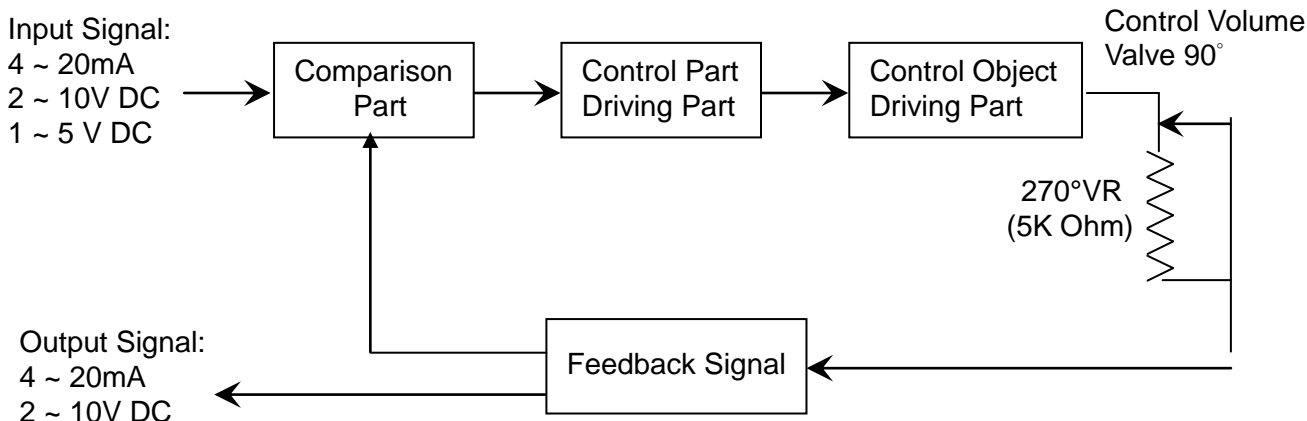

Supplied Voltage : 24V DC / AC, 110V / 220V AC 1- Phase

3. DIP-SWITCH SETTING (SW1)

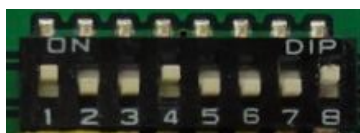

↑ ON
↓ OFF

	1	2	3	4	5	6	7	8
Factory setting	ON	OFF	OFF	ON	OFF	OFF	OFF	ON
4~20mA input	ON	OFF						
1~5V input	OFF	OFF						
2~10V input	OFF	ON						
4~20mA output			OFF	ON	OFF			
2~10V output			ON	OFF	ON			
20mA / 5V / 10V means valve fully-open						OFF		
20mA / 5V / 10V means valve fully-closed						ON		
Close valve if input signal disconnected (when S6 sets " OFF")							OFF	ON
Open valve if input signal disconnected (when S6 sets " OFF")							ON	OFF
Actuator will not operate if input signal disconnected (when S6 sets " OFF")							ON	ON
							OFF	OFF

NOTE:

1. After completing dip-switch setting, restart the actuator.
2. The standard factory presetting is 1, 4, 8 for ON and 2, 3, 5, 6, 7 for OFF.

ADJUSTMENT – Modulating Control Board

Part A: Suitable for OM-1~OM-13、OM-A、OM-A-M、OM-F、OM-G

	FUNCTION	SETTING
S1, 2	INPUT SIGNAL SELECT.	“4~20mA” set 1-ON / 2-OFF. “1~5V” set 1-OFF / 2-OFF. “2~10V” set 1-OFF / 2-ON.
S3, 4, 5	OUTPUT SIGNAL SELECT.	“4~20mA” set 3-OFF / 4-ON / 5-OFF. “2-10V” set 3-ON / 4-OFF / 5-ON.

When S6 sets “ON ”

S6	INPUT SIGNAL SELECT : 4mA, 2V, 1V →valve fully-open. 20mA, 10V, 5V →valve fully-closed.	Set 6-ON.
S7, 8	POSITION SELECT. (When the input signal fails.)	“valve fully-closed” set 7-ON / 8-OFF. “valve fully-open” set 7-OFF / 8-ON. “valve stops” set 7-ON / 8-ON. or 7-OFF/ 8-OFF.

When S6 sets “OFF ”

S6	INPUT SIGNAL SELECT : 4mA, 2V, 1V →valve fully-closed. 20mA, 10V, 5V→valve fully-open.	Set 6-OFF.
S7, 8	POSITION SELECT. (When the input signal fails.)	“valve fully-closed” set 7-OFF / 8-ON. “valve fully-open” set 7-ON / 8-OFF. “valve stops” set 7-ON / 8-ON. or 7-OFF / 8-OFF.

ADJUSTMENT – Modulating Control Board

Part A: Suitable for OM-1~OM-13、OM-A、OM-A-M、OM-F、OM-G

4. Sensitivity Switch Setting(SW2)

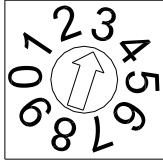

- a. When switch to “1”: The Highest Sensitive and the 0~90 degree can be divided up to around 50 times movement.
- b. When switch to “0”: The Lowest Sensitive and the 0~90 degree can be divided up to around 10 times movement.
- c. The sensitivity decreases 5 times movement by sectors from SW1 to SW2, SW2 to SW3, SW3 to SW4 and so on.

5. Settings for OPEN and CLOSE (OM-1, OM-A, OM-A-M)

The settings are set at factory, though in some cases re-set may be required when a particular rate of signal is requested.

Adjust output signal/input signal

- VR1— Adjust 10V, 20mA (Input signal: fully-open)
 - VR51— Adjust 10V, 20mA (Output signal: fully-open)
 - VR2 — Adjust 2V, 4mA (Input signal: fully-closed)
 - VR52 — Adjust 2V, 4mA (Output signal: fully-closed)
- } The function of VR

Note: If it is necessary to adjust VR51 and VR52, VR1 and VR2 also need to be adjusted accordingly.

- a. Rotate VR1 counterclockwise until a light click is heard, then supply 10V (or 20mA) to modulating board. Slightly rotate VR1 clockwise until green LED keeps on. Adjust VR51 to complete.

- VR51 : ⤴ Clockwise: decreasing signal.
- ⤵ Counterclockwise: increasing signal.

- b. Rotate VR2 clockwise until a light click is heard, then supply 2V (or 4mA) to modulating board. Slightly rotate VR2 counterclockwise until red LED keeps on. Adjust VR51 to complete.

- VR52 : ⤴ Clockwise: decreasing signal.
- ⤵ Counterclockwise: increasing signal.

ADJUSTMENT – Modulating Control Board

Part A: Suitable for OM-1~OM-13、OM-A、OM-A-M、OM-F、OM-G

6. Settings for OPEN and CLOSE (OM-2~OM-13、OM-F、OM-G)

The settings are set at factory, though in some cases re-set may be required when a particular rate of signal is requested.

OPEN setting



- a. Keep pressing “SET” for 2 seconds, then LD 9 comes on, it will enter to the manual mode.
- b. Keep pressing “UP” until actuator runs to fully-open position, LD2 comes on, then supplies the input signal (5V or 10V or 20mA).
- c. Press “MODE” once. The OPEN setting is completed.

CLOSE setting

- a. Keep pressing “DOWN”, until actuator runs to fully-closed position, LD1 comes on , then supplies input signal (1V or 2V or 4mA).
- b. Press “MODE” once. The CLOSE setting is completed.

After completing the above settings, press “SET” once

Adjust output signal

- VR2 :  Clockwise: increasing signal.
 Counterclockwise: decreasing signal.

ADJUSTMENT – Modulating Control Board

Part A: Suitable for OM-1~OM-13、OM-A、OM-A-M、OM-F、OM-G

7. Lamp Signal (OM-2~OM-13、OM-F、OM-G)

LD1	Fully-closed	LD6	Motor thermostat turn off
LD2	Fully-open	LD7	Output signal short circuit
LD3	Power	LD8	Motor current is excessive
LD4	Abnormal Voltage	LD9	Manual Mode
LD5	Wrong input signal		

If the LED (LD4~LD9) is flashing under modulating control, refer to the following "Modulating Board Troubleshooting".

Lamp	Possibilities	Solution
No Lamp (LD3 off)	a. No power supply. b. The voltage is over 260V to cause the board burn out. c. Wrong connecting for the #8, #9 of the VR. d. Faulty Modulating board.	a. Check the power supply and wiring (#4 & #5 of modulating board). b. Check the voltage. c. Check the wiring. d. Send back to factory for inspection.
LD5	a. Setting in 2-10V input signal but supply 4-20mA. b. Setting in 2-10V input signal, but the input signal is over 13.5V. **Setting in 4-20mA but supply 2-10V signal. The actuator could still be operated within 2~7V. But if the signal is over 7.2V the LED5 will come ON.	Confirm if the input signal is the same as dip switch setting (refer to P54~P55).
LD 6	Motor thermostat turns off.	a. Too high frequency for rated duty cycle(refer to P2). b. Motor thermostat (MOT) is not connected.
LD7	a. Output signal short circuit. b. Wrong connecting of the 2-10V input signal.	a. Confirm the wiring of output signal #11(-) 、 #12(+). b. Confirm the input signal for #6(-) 、 #7(+).
LD8	Motor current is excessive.	a. Too high frequency for rated duty cycle (refer to P2). b. Check the load (refer to P4~P5). c. Check if the motor rotor is locked (For example: Valve is stuck by foreign objects).
LD9	Manual Mode - Setting position for open & close.	After completing the settings, press "SET" once.

ADJUSTMENT – Modulating Control Board

Part B: Suitable for OM-1、OM-A、OM-A-M (Option: MODBUS)

1. Surface

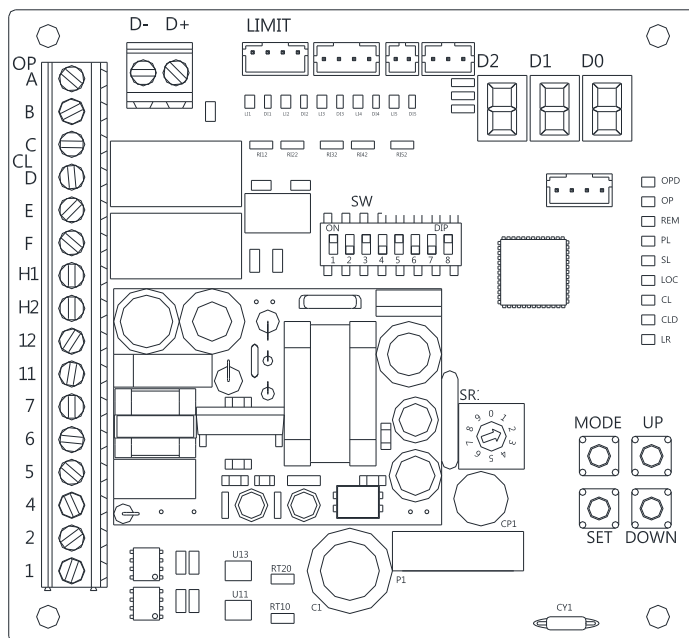

2. Procedure

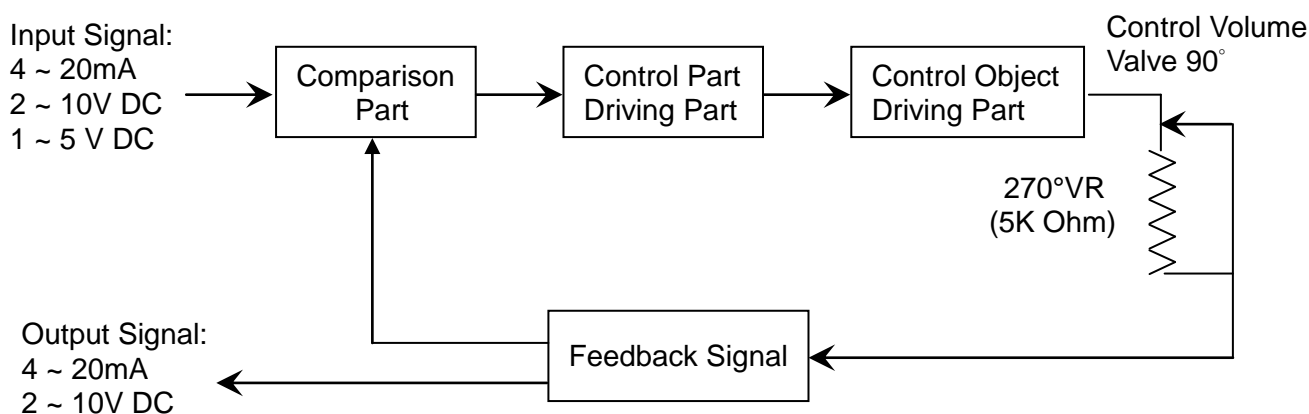

ADJUSTMENT – Modulating Control Board

Part B: Suitable for OM-1、OM-A、OM-A-M (Option: MODBUS)

3. DIP-SWITCH SETTING (SW)



Analog signal output

8	7	6	5	4	3	2	1								
ON	OFF	OFF	OFF	ON	OFF	OFF	ON	Factory setting							
								OFF	ON	4-20mA input					
								OFF	OFF	1-5V input					
								ON	OFF	2-10V input					
								OFF	ON	OFF	4-20mA output				
								ON	OFF	ON	2-10V output				
								OFF	20mA / 5V / 10V means valve fully-open						
								ON	20mA / 5V / 10V means valve fully-closed						
								ON	OFF	Close valve if input signal disconnected (when S6 sets “ OFF”)					
								OFF	ON	Open valve if input signal disconnected (when S6 sets “ OFF”)					
ON	ON	Actuator will not operate if input signal disconnected													
OFF	OFF	(when S6 sets “ OFF”)													

MODBUS

8	7	6	5	4	3	2	1	
			ON	ON	ON	ON	ON	MODBUS
OFF	OFF	OFF	Actuator will not operate if input signal disconnected					

NOTE:

1. After completing dip-switch setting, restart the actuator or wait for 5 secs.
2. The standard factory presetting is 1, 4, 8 for ON and 2, 3, 5, 6, 7 for OFF.

ADJUSTMENT – Modulating Control Board

Part B: Suitable for OM-1、OM-A、OM-A-M (Option: MODBUS)

Analog signal output

Dip-switch Setting	FUNCTION	SETTING
S1, 2	INPUT SIGNAL SELECT.	“ 1~5V ” set 1-OFF / 2-OFF. “ 2~10V ” set 1-OFF / 2-ON. “ 4~20mA ” set 1-ON / 2-OFF.
S3, 4, 5	OUTPUT SIGNAL SELECT.	“2-10V” set 3-ON / 4-OFF / 5-ON. “4-20mA” set 3-OFF / 4-ON / 5-OFF.

When S6 sets “ ON ”

S7, 8	POSITION SELECT (When the input signal fails)	“valve fully-closed” set 7-ON / 8-OFF. “valve fully-open” set 7-OFF 8-ON. “valve stops” set 7-ON / 8-ON.Or 7-OFF / 8 - OFF.
-------	--	---

When S6 sets “ OFF ”

S7, 8	POSITION SELECT (When the input signal fails)	“valve fully-closed” set 7-OFF 8-ON. “valve fully-open” set 7-ON / 8-OFF. “valve stops” set 7-ON / 8-ON.Or 7-OFF / 8 - OFF.
-------	--	---

MODBUS

Dip-switch Setting	FUNCTION	SETTING
S1~5	MODBUS SELECT	MODBUS set 1~5-ON.
S6~8	POSITION SELECT (When the input signal fails)	“valve stops” set 7-OFF / 8 - OFF.

ADJUSTMENT – Modulating Control Board

Part B: Suitable for OM-1、OM-A、OM-A-M (Option: MODBUS)

4. Sensitivity Switch Setting (SR1)

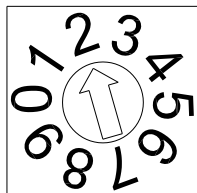

1. Factory setting for software edition U20 is 3.
 Factory setting for software edition U21 is 0.
 * The software edition will be displayed on LED indication when the actuator powers on.
2. When switching to "1", it will respond at the highest level of sensitivity.
 When switching to "0", it will respond at the lowest level of sensitivity.
3. The factory setting of the accumulated variation in sensibility for each movement is 0.3mA
 and the total variation can be divided into approx. 54 movements.

5. Lamp Indication

Lamp	Actuator Status
OPD	Fully-open position
OP	Opening direction
REM	Remote control mode
PL	Alerting signal
SL	Setting mode
LOC	Local control mode
CL	Closing direction
CLD	Fully-closed position

ADJUSTMENT – Modulating Control Board

Part B: Suitable for OM-1、OM-A、OM-A-M (Option: MODBUS)

6. LED Indication

a. Setup flow chart

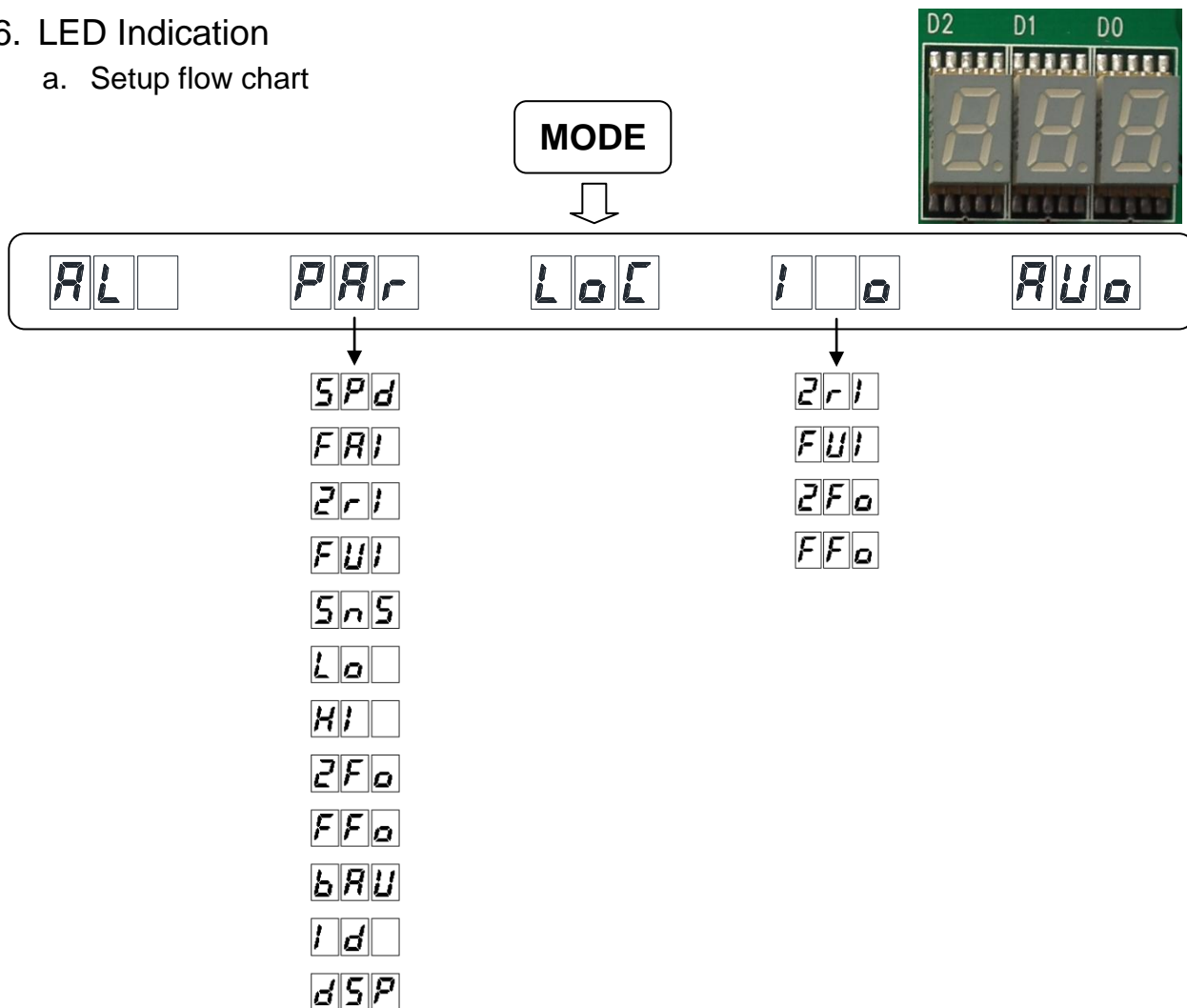

ADJUSTMENT – Modulating Control Board

Part B: Suitable for OM-1、OM-A、OM-A-M (Option: MODBUS)

b. The function of LED indication

LED indication	Function
AL	Error log
PAR	Basic parameter
LoC	Local control
Io	Fast setting
AUo	Auto run
SPd	Running time setting
FRI	Wrong input signal
2r1	Input signal setting for fully-closed position
FUI	Input signal setting for fully-open position
SnS	Sensitivity Setting
Lo	Fully-closed position setting
Hi	Fully-open position setting
2Fo	Output signal setting for fully-closed position
FFo	Output signal setting for fully-open position
bRU	Baud rate setting for MODBUS
Id	Station setting for MODBUS
dSP	Display setting

ADJUSTMENT – Modulating Control Board

Part B: Suitable for OM-1、OM-A、OM-A-M (Option: MODBUS)

7. Adjustable Speed Setting

- a. Press “MODE” several times to get into PAr, then press “SET” once to enter parameter setting mode.
- b. Get into SPd and keep pressing “SET” (around 3 sec) to enter setting mode.
- c. Adjust with “UP” and “DOWN” to the required selection.

Selection	1	2	3	4	5	6	7	8	9	10
Running time (Sec.)	Standard	30	60	80	100	120	150	180	200	200

- d. Press “SET” once to complete the adjustable speed setting.
- e. Press “MODE” five times to go back to position indicator to complete the setting.

8. Travel Setting

- a. Press “MODE” five times to get into AUo.
- b. Keep pressing “SET” (around 5 sec) until “LOC” comes on, entering the Auto run mode.
- c. When the Auto run is completed, “LOC” comes off and the actuator will stop running.
The travel setting is completed.

ADJUSTMENT – Modulating Control Board

Part B: Suitable for OM-1、OM-A、OM-A-M (Option: MODBUS)

9. Signal Setting



If the travel setting could not satisfy your request, the signal is needed to be adjusted separately, please follow the steps of signal setting.

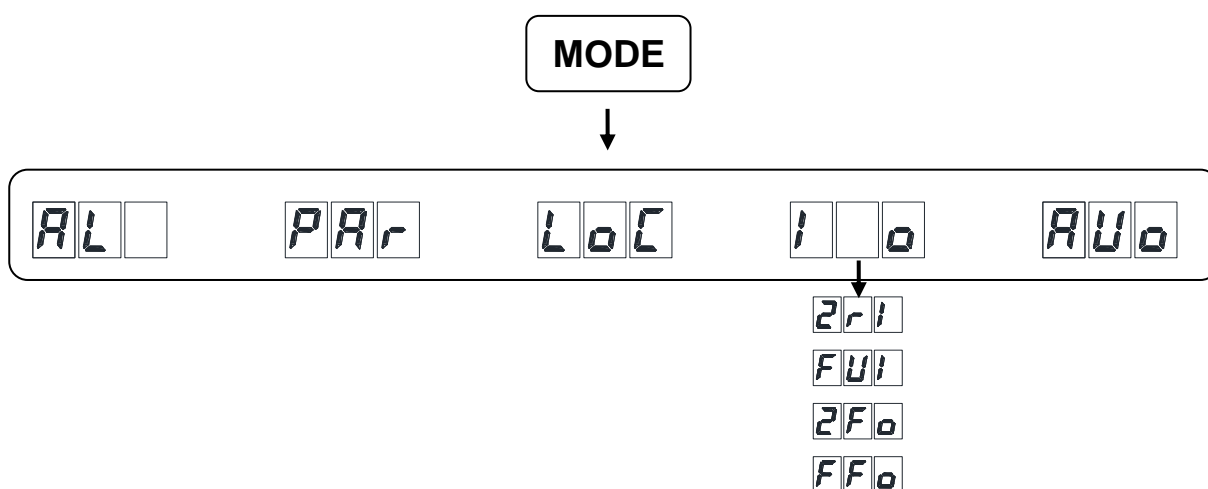



Input signal setting for fully-closed position

- Press “MODE” several times until get into **I o**, then press “SET” once to enter signal setting mode.
- Get into **2r1**, and keep pressing “SET” (around 3 sec) until **2r1** is glittering.
- Supply the input signal according to the dip switch setting (1V or 2V or 4mA).
- Press “SET” once and “MODE” twice to complete the input signal setting for fully-closed position.

ADJUSTMENT – Modulating Control Board



Part B: Suitable for OM-1、OM-A、OM-A-M (Option: MODBUS)

Input signal setting for fully-open position

- Press “MODE” several times until get into , then press “SET” once to enter signal setting mode.
- Adjust with “UP” and “DOWN” until get .
- Keep pressing “SET” (around 3 sec) until  is glittering.
- Supply the input signal according to the dip switch setting (5V or 10V or 20mA).
- Press “SET” once and “MODE” twice to complete the input signal setting for fully-open position.



Output signal setting for fully-closed position

 **Install the ammeter or monitor to correspond to output signal setting**

- Press “MODE” several times until get into , then press “SET” once to enter signal setting mode.
- Adjust with “UP” and “DOWN” until get into .
- Keep pressing “SET” (around 3 sec).
- Adjust the output value with “UP” and “DOWN” until the value can fit with your request.
- Press “SET” once and “MODE” twice to complete the output signal setting for fully-closed position.

Output signal setting for fully-open position

 **Install the ammeter or monitor to correspond to output signal setting**

- Press “MODE” several times until get into , then press “SET” once to enter signal setting mode.
- Adjust with “UP” and “DOWN” until get .
- Keep pressing “SET” (around 3 sec).
- Adjust the output value with “UP” and “DOWN” until the value can fit with your request.
- Press “SET” once and “Mode” twice to complete the output signal setting for fully-open position.

ADJUSTMENT – Modulating Control Board

Part B: Suitable for OM-1、OM-A、OM-A-M (Option: MODBUS)

10. Warning Message

- a. Press "MODE" once to get into AL , then press "SET" once to get into warning message.
- b. Adjust with "UP" and "DOWN" to review the history log of warning message.

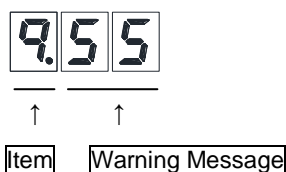



<u>Item (9,8,7...0)</u>	<u>Warning Message</u>	<u>Solution</u>
<div style="display: flex; flex-direction: column; align-items: center;"> <div style="display: flex; align-items: center; margin-bottom: 5px;"> <div style="border: 1px solid black; padding: 2px; margin-right: 5px;">9.</div> <div style="color: red;">(The latest data)</div> </div> <div style="border: 1px solid black; padding: 2px; margin-bottom: 5px;">8.</div> <div style="border: 1px solid black; padding: 2px; margin-bottom: 5px;">7.</div> <div style="border: 1px solid black; padding: 2px; margin-bottom: 5px;">6.</div> <div style="border: 1px solid black; padding: 2px; margin-bottom: 5px;">5.</div> <div style="border: 1px solid black; padding: 2px; margin-bottom: 5px;">4.</div> <div style="border: 1px solid black; padding: 2px; margin-bottom: 5px;">3.</div> <div style="border: 1px solid black; padding: 2px; margin-bottom: 5px;">2.</div> <div style="border: 1px solid black; padding: 2px; margin-bottom: 5px;">1.</div> <div style="border: 1px solid black; padding: 2px; margin-bottom: 5px;">0.</div> </div> <div style="text-align: right; margin-top: 5px;">(The oldest data)</div>	<div style="display: flex; flex-direction: column; align-items: center; margin-bottom: 10px;"> <div style="border: 1px solid black; padding: 2px; margin-bottom: 5px;">01</div> <div>Wrong Input signal.</div> </div> <div style="display: flex; flex-direction: column; align-items: center;"> <div style="border: 1px solid black; padding: 2px; margin-bottom: 5px;">55</div> <div>No abnormal records.</div> </div>	<ol style="list-style-type: none"> a. Input signal fails. b. Check if the input signal and dip switch setting are correct.

※ The latest data will stay with the item 9.

ADJUSTMENT – Modulating Control Board

Part B: Suitable for OM-1、OM-A、OM-A-M (Option: MODBUS)

c. Example

- If you want to check the latest data, press "MODE" several times until get into  → Press "Set" once → The LED display will show the latest data .
- If you want to check eighth data, press "MODE" several times until get into  → Press "SET" once → Press "DOWN" seven times and the LED display will show the eighth data.



11. MODBUS Setting



MODBUS and modulating controller can not be operated at the same

① Adjust the dip switch (SW) Pin1~ Pin5 to "ON" position ; Pin6~ Pin8 to "OFF" position.

② Baud rate setting

- Press "MODE" twice until get into .
- Press "SET" once to get into .
- Press "DOWN" ten times to enter to .
- Keep pressing "SET" (around 3 sec) until the LED indicator is glittering to get into setting mode.
- Adjust with "UP" and "DOWN" to set baud rate for MODBUS. Adjust to your demand value. (default valve #4)

Setting Value	Baud rate
4	9600
5	19200

f. Press "SET" once to complete the setting.

ADJUSTMENT – Modulating Control Board

Part B: Suitable for OM-1 、 OM-A 、 OM-A-M (Option: MODBUS)

③ Station Setting

- a. Press “DOWN” once to get into  .
- b. Keep pressing “SET” (around 3 sec) until the LED indicator is glittering to get into setting mode.
- c. Adjust with “UP” and “DOWN” to set the station. (Station Range:1~127, default Station: 1)
- d. Press “Set” once to complete the setting.

④ Press “Mode” four times to back to home page.

TROUBLE SHOOTING

ON-OFF Controller

1. Motor does not operate and overheats

Possibilities	Solution
a. Supply power to #3 · #4 simultaneously (Parallel Connection).	a. Check the wiring (For coupling wiring, refer to P48).
b. The capacitor failed (whether the surface of the capacitor deforms).	b. Replace to a new part.
c. Valve’s rubber is getting hardened or the valve’s torque is excessive (it takes longer time to reach fully-closed position).	c. Use hand-wheel for test or change to a new valve.
d. Foreign objects in the flow stream.	d. Check if any obstructions
e. Broken motor stem or bearing.	e. Replace to a new parts
f. The limit switch for fully-closed does not trip.	f. Operate the actuator manually to fully-closed position and confirm if the limit switch trips.

2. The actuator is operated very well but the motor is hot.

Possibilities	Solution
a. Actuator operates too frequently (Starting frequency is too high).	a. Change system bandwidth or replace to a higher duty cycle actuator (refer to P2).
b. Overload.	b. This situation often happens after operating for a long time. It is suggested to replace to a new valve.
c. Under or over rated voltage.	c. Check the supply circuit (refer to P4~P5).
d. Mechanical stops are reached by the gear train at fully-open or fully-closed position.	d. Reset the mechanical stops and cam (TC1 & TC2) (refer to P49~P52).
e. Wrong power supply.	e. Check the power supply.

3. When operating two or more actuators simultaneously, the actuator works abnormally some times and the motor is getting hot.

Possibilities	Solution
Parallel connection.	a. Check current values and install a relay respectively. (refer to wiring diagram P48)

TROUBLE SHOOTING

4. The valve can not fully-open or fully-closed by either power supply or hand-wheel.

Possibilities	Solution
a. The actuator does not mount with the valve tightly during installation process.	a. Contact technical department to solve the problem.
b. The torque of valve is larger than the torque of actuator.	b. Replace to a new valve or a larger actuator.
c. The set screw of the cam is loose.	c. Readjust the mechanical stops and limit switches (refer to P49~P52).
d. The installing angle of actuator and valve is not correct.	d. Check the angle of the valve and actuator.

5. The capacitor is failed.

Possibilities	Solution
a. Overload (exceed the rated torque of actuator).	a. Replace to a new part. It's suggested to change a new valve or a larger actuator.
b. Starting frequency is too high or ambient temperature is too high.	b. Replace to a new part and change to 75% duty cycle actuator (refer to P2).
c. Over service life.	c. Check the capacitance and surface every year.

Modulating Controller

1. The LED (LD5~LD9) is flashing after the operating check is completed.

Solution
Refer to P58.

2. The lamps on the modulating board are normal but the actuator can't work properly during test or it only can turn to fully open/closed position.

Possibilities	Solution
The signal is connected oppositely (means to signal failure).	Confirm if the input signal and the wiring are correct (terminal #6 connects to “-“ and terminal #7 connects to “+”).

3. Can not operate by modulating controller.

Possibilities	Solution
a. Faulty VR.	a. Replace to a new VR.
b. The sector gear of the VR is loose.	b. Remove the input signal wires. Operate the actuator to fully-closed. Then readjust the VR (refer to P49~P51).
c. Wrong input signal.	c. Check if the input signal is correct (refer to P49~P51).
d. Faulty modulating board.	d. Send back to factory for inspection.

WARRANTY

Sun Yeh Ele. Co. Ltd warrants that for a period of twelve months from the date of manufacture it will either repair or replace, at its option, any of its products which prove to be defective in material or workmanship. This warranty does not cover damage resulting from causes such as abuse, misuse, modification or tampering by users.

This warranty is extended only to the immediate purchaser of Sun Yeh product and is not transferable.

To obtain service under this warranty, the purchaser must first acquire a return authorization from Sun Yeh. Products must be returned to Sun Yeh under freight prepaid.

This warranty is in lieu of all other obligations, liabilities or expressed warranties. Any implied warranties, including any implied warranty of merchantability are hereby expressly excluded. In no event shall Sun Yeh be liable for special, incidental or consequential damages arising in connection with the use of its products, or for any delay in the performance of this warranty due to cause beyond its control.